



# DESIGN FOR THE FUTURE

GERALD D. HINES  
COLLEGE OF  
ARCHITECTURE  
AND DESIGN  
2020-2022 REPORT





## TABLE OF CONTENTS

---

Forward .....	2
Our Vision .....	5
Our Mission .....	5
Goals .....	6
College Performance Measures .....	20
NAAB Accreditation .....	22
<i>Studio of the Future</i> Charette Week .....	23
Leadership Council .....	24
Hines College Mourns Passing of Former Dean .....	28
Hines College Celebrates Historic 75 <sup>th</sup> Anniversary .....	30
Architecture .....	34
Architecture Stories .....	38
Industrial Design .....	68
Industrial Design Stories .....	70
Interior Architecture .....	82
Interior Architecture Stories .....	83
Design/Build .....	86
Design Build Stories .....	86
Center for Sustainability and Research (CeSAR) .....	88
CeSAR Stories .....	89
Community Design Research Center (CDRC) .....	92
Materials Research Collaborative (MRC) .....	94
Construction Robotics and Fabrication Technology (CRAFT) Lab .....	95
designLAB .....	98
Career Development .....	101
New Scholarships .....	102
Faculty .....	104
Faculty Recognition and Awards .....	108
Student Recognition and Awards .....	128





## FORWARD

WHILE WE ALL EMERGE FROM THE PANDEMIC, I AM RE-ENERGIZED BY THE PROMISE OF THE COMING YEAR.

Even as the impact of COVID-19 pulled us into isolation, the Hines College continued surging forward with the University, facing the future with the “top 50” goal in front of us. We join with the University, united in our shared vision of sustainable and resilient communities and cities, of Houston - post-oil/post-sprawl, and of solving the ever-pressing healthcare challenges facing our populations. Our College stepped up, with our colleagues in Engineering, to add our expertise to the research agenda. Joining our faculty this coming fall are two new Presidential Frontiers assistant professors: Elham Morshedzadeh and Dalia Munenzon. I know our faculty will welcome them and go out of their way to assure their success.

At the beginning of the spring semester, we launched a week-long College Design Charrette focused on the *Studio of the Future*. The week-long effort yielded more than 400 pages of ideas, drawings, plans, and proposals, giving us a glimpse into the future through the eyes of our students and faculty. We have begun to distill this work into a series of questions and provocations forming the backbone of our new strategic plan, launching in earnest this fall. Our strategic plan will thrust us toward the University’s centennial celebration in 2027. It is impossible to not look toward 2022–2023 without excitement and optimism for what is on the horizon for the College.

This annual report is a little different than past annual reports. We did not create an annual report for 2020. We had our minds and souls consumed by surviving the pandemic and struggling to provide the best education for our students in those unprecedented circumstances. This report will cover from fall 2020 and into spring of 2022. It is an attempt to celebrate what the College was able to do even in the crush of the worst world crisis of our time. I hope you will share the pride I feel in what our faculty, students, staff, and alumni have accomplished and the promise of what awaits us.

**Patricia Belton Oliver, FAIA, Dean**  
ACSA Distinguished Professor  
Director, *designLAB*



It is impossible to not look toward 2022–2023 without excitement and optimism for what is on the horizon for the College.

**THIS PAGE:** STUDENTS WERE THRILLED TO RETURN TO THE HINES COLLEGE TO CELEBRATE THE SPRING 2022 COMMENCEMENT.





## OUR VISION

---

**WE STRIVE TO BECOME A PREMIER COLLEGE OF ARCHITECTURE AND DESIGN** and to produce critical thinkers and global citizens who are skilled in their craft, capable of using advanced technology and methods of industrialized production; respect the environment; understand the power of design to shape many lives; and are equipped to take on leadership roles within their chosen professions.

## OUR MISSION

---

**THE GERALD D. HINES COLLEGE OF ARCHITECTURE AND DESIGN** at the University of Houston remains focused on design as the fundamental activity of its studies since 1956.

Building on that focus, the College positions itself to:

- Explore solutions to society's myriad challenges through reflection and action with the prospect of advancing the human condition
- Practice with respect for the environment
- Foster innovation through collaboration
- Instill a global view of design and the arts and prepare students to serve as cultural leaders of the 21<sup>st</sup> century
- Advance our professions through scholarship and research
- Benefit Houston and the greater urban environment through service to the University, our communities, industry, government, and the architecture and design professions

**OPPOSITE PAGE:** STUDENTS  
AT THE COLLEGE LEARN  
INVALUABLE DESIGN LESSONS  
THROUGH STUDIO CRITIQUES



# GOALS

## GOAL ONE: BUILD A LOCAL, NATIONAL, AND INTERNATIONAL VALUE NETWORK

### STUDENT WORK GOES INTERNATIONAL

During the pandemic, the College's City of Refugees exhibition opened at Aedes Architecture Forum alongside international artist and activist Ai Weiwei's *Purgatory*. This was the College's second time exhibiting at Europe's most prestigious architecture gallery, an institution that rarely welcomes student work.

### PUBLICATIONS BOUNCE BACK FROM PANDEMIC

In 2021, faculty scholarly publications increased to a record-breaking 105. Prior to the pandemic, the College's scholarly publications steadily increased to a peak of 91 per year. During the pandemic, scholarly publications dropped due to the cancellation of many annual conferences.



**THIS SPREAD:** CITY OF REFUGEES  
STUDENT WORK DISPLAYED AT THE  
AEDES ARCHITECTURE FORUM, EUROPE'S  
MOST PRESTIGIOUS ARCHITECTURE  
GALLERY, 2020







## **GOAL TWO: DEVELOP OUR LOCAL REPUTATION INTO A NATIONAL AND GLOBAL REPUTATION**

### **LEADERSHIP AMONG DISTINGUISHED PROFESSORS**

Dean Patricia Belton Oliver, FAIA, currently serves in an elected position on the Association of Collegiate Schools of Architecture (ACSA) College of Distinguished Professors Executive Committee, where she will assume the role of Chancellor in July 2022.



### **FACULTY WIN NATIONAL COURSE DEVELOPMENT AWARD**

Professors Matthew Johnson and Michael Kubo were selected for the 2021 Course Development Prize in Architecture, Climate Change, and Society awarded through a partnership with the Association of Collegiate Schools of Architecture (ACSA) and the Columbia University Temple Hoyne Buell Center for the Study of American Architecture. Their proposal combined the professors' shared interest in the impacts of petrochemical culture with a focus on environmental justice.



### **INDUSTRIAL DESIGN PROFESSORS EARN NATIONAL HONORS**

Industrial Design Professor George Chow was named the 2021 National IDSA Young Educator for his significant impact to Industrial Design education within the early years of his academic career.



In February 2022, associate professor Jeff Feng was one of 83 members elected by The National Academy of Inventors (NAI) Senior Member Advisory Committee and Board of Directors to the Class of 2022 NAI Senior Members for his success in licensing, patents, commercialization, and producing technologies impacting the welfare of society.

### **STUDENTS TRAVEL TO SOUTH BY SOUTHWEST (SXSW)**

With sustaining support from the William Stamps Farish Fund, the Industrial Design program exhibited at the 2022 annual SXSW conference with the goal of building a more expansive network and helping students sell their designs.

#### **TOP TO BOTTOM:**

MATTHEW JOHNSON,  
MICHAEL KUBO, GEORGE  
CHOW, AND JEFF FENG

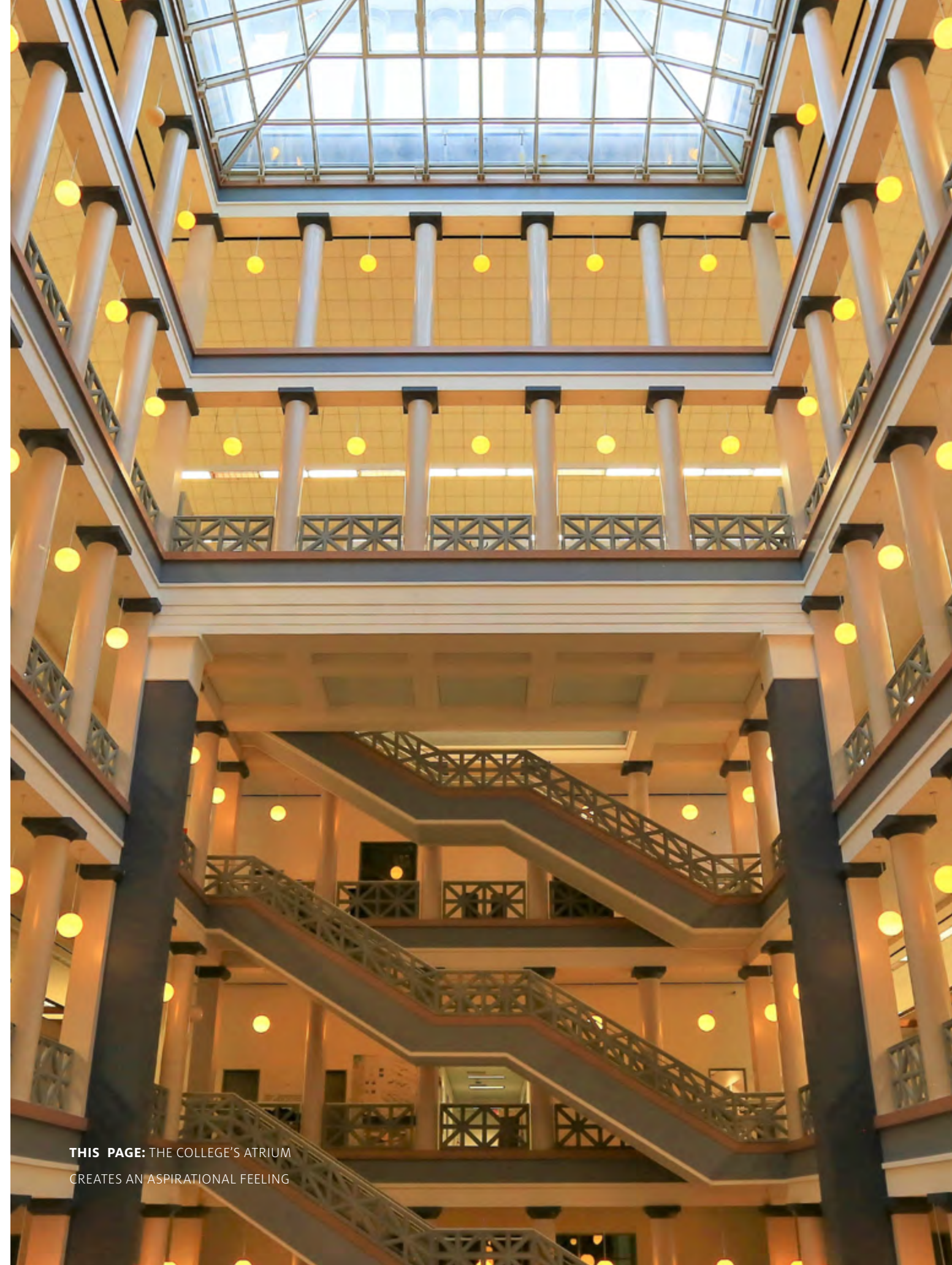

**THIS PAGE:** THE COLLEGE'S ATRIUM  
CREATES AN ASPIRATIONAL FEELING





**THIS PAGE:** THE COLLEGE SUPPORTS STUDENT SUCCESS THROUGH A MYRIAD OF TEACHING METHODOLOGIES

## **GOAL THREE: DEVELOP AN INTEGRATIVE MODEL FOR ARCHITECTURAL EDUCATION**

### **MULTICULTURAL STUDIES INITIATIVE GRANT**

Professor Tom Diehl received a \$27,000 Multicultural Studies Initiative Grant for his proposal *Visual Envisioning Future Urban Realities*. The grant funds his experiment with augmented and virtual realities as a delivery tool for better understanding of building and materials decisions in construction. Research in this area and integration into the College's curriculum better prepares students to adapt to changing industry skills and standards.



### **TECHNOLOGY ENHANCES STUDENT EXPERIENCES**

Over the last several years, the addition of Co-coordinators of Technology have played an integral role in faculty discussions and planning for the integration of technology into studio classes. In 2021, under the development of Andrew Kudless, the College's Coordinator of Design Media, the College began delivering mini sessions in media design and sketching for the first time in response to students' requests for more design media tutorials.



### **GOING BEYOND THE WORKSHOP**

Assistant Professor of Architecture and Urbanism Deepa Ramaswamy received a 2021 grant from the Global Architectural History Teaching Collective and The Andrew W. Mellon Foundation funding a workshop critically examining architectural history survey courses. The series of workshop sessions, *Going Beyond the Survey*, were held at the beginning of the spring 2022 semester and provided insights into other contexts, disciplines, and universities that will undoubtedly advance the HTC program at the Hines College.

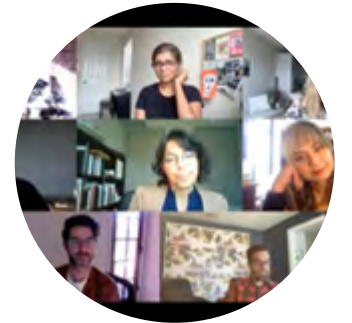

**TOP TO BOTTOM:** TOM DIEHL; ANDREW KUDLESS; A SCREENSHOT OF THE *GOING BEYOND THE SURVEY* WORKSHOP



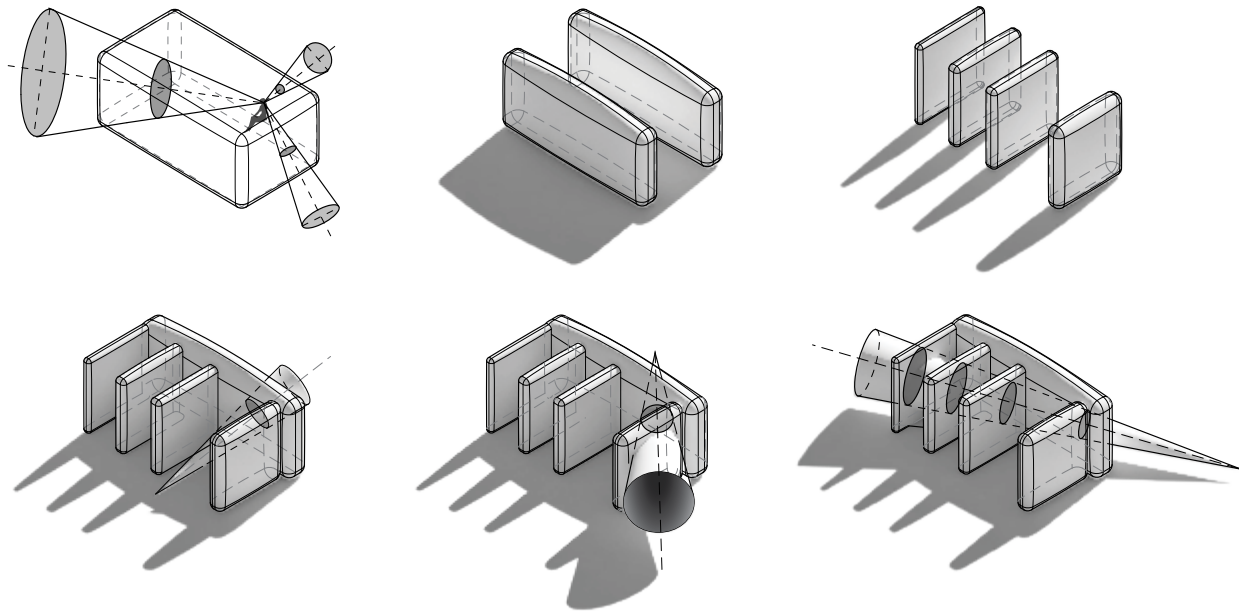

## GOAL FOUR: GROW AND EXPAND OUR GRADUATE PROGRAMS

### URBAN DESIGN AND SUSTAINABLE COMMUNITIES

The movement toward an Urban Design and Sustainable Communities degree option in the Graduate Architecture program is beginning to take shape. Currently a concentration, the College is now developing a critical mass of faculty to move forward with a degree option in this area. In 2021, President Khator awarded the Hines College a Presidential Frontier Faculty grant to hire an additional faculty member in the area of Sustainability, shared 75% Architecture and 25% Engineering. The new faculty member, Dalia Muenezon (beginning fall 2022), along with Matt Johnson, Bruce Race, Shafik Rifaat, and Susan Rogers will allow this program to reach its developmental goal. The College has also endowed a future chair for the program through a bequest from alumnus and Leadership Council member Joe Webb '71.

### GRADUATE ARCHITECTURE STRATEGIC PLAN

The Graduate Architecture program continues to make advances on its strategic plan to 1) be among the most highly respected public design learning institutions in the world; 2) to sustain and enhance excellence in scholarship, creative inquiry, critical practice, research, and ensure that design prowess, leadership in practice, innovation and entrepreneurship in all regards working in service of the city and the public are fundamental characteristics of the College's graduates.

ABOVE: GRADUATE STUDENT WORK ILLUSTRATING COMPOUND FIGURATIONS

## GOAL FIVE: ATTRACT AND RETAIN THE BEST STUDENTS

### A FOCUS ON RECRUITMENT

The College increased the number of appearances at recruitment events and published its very first *Prospectus* giving a detailed look into the Undergraduate Architecture curriculum and student work produced through the program.

In 2020, the College launched a new dedicated recruiting webpage giving prospective students a more in-depth look into architecture and design at UH.

### LARGEST CAREER FAIR TO DATE

In 2022, the Hines College hosted its largest career fair to date with 51 employers, 82 job postings, 1,788 applications, and 357 scheduled interviews.

### FIVE NEW SCHOLARSHIPS ADDED

During 2021-2022, the College added five new endowed student scholarships to its breadth of financial support opportunities, including scholarships specifically for graduate students.

AT RIGHT: FUTURE STUDENTS CAN SEE WHAT THE COLLEGE OFFERS ON THE RECRUITING WEBPAGE





**THIS SPREAD:** AN INTERIOR  
RENDERING AND THE EXTERIOR VIEW  
OF THE CRAFT LAB



**GOAL SIX: DEFINE  
MEDIA, DIGITAL  
FABRICATION,  
AND DIGITAL  
VOCABULARIES FOR  
THE COLLEGE**

**NEW CRAFT LAB UNDERWAY**

During the pandemic, the College completed construction on Phase I of the CRAFT Lab, with hopes of seeing Phase II come to fruition by the end of 2022. The College's 75th Anniversary Gala in October 2021 raised \$450,000 supporting Phase II of the Lab, as well as student scholarships.

**ENDOWED KENDALL PROFESSOR**

The College raised over \$1 million establishing the Bill Kendall Memorial Endowed Professorship in Design Technologies. Andrew Kudless, known internationally as being the only American to have a piece in the Louis Vuitton *Objets Nomades* collection, now celebrating ten years in 2022, holds the inaugural Kendall Professorship.



## GOAL SEVEN: DEVELOP A ROBUST RESEARCH AGENDA FOR THE COLLEGE

### RESEARCH AND AWARDED GRANTS ON THE RISE

In 2021, the College's Center for Sustainability and Resilience (CeSAR) continued expanding its reach, receiving its first \$1 million grant from the National Science Foundation, shared with the UH College of Technology, Vanderbilt University, and the University of Texas Health Science Center.

Interim Director of Interior Architecture Sheryl Tucker de Vazquez was awarded a prestigious 2021 Graham Foundation grant for her proposal "Hair Salon: Translating Black Hair Practices for Architecture Using Computational Methods." The grant explores how Black hair natural texture and skills translate to architecture through computational methods.

Professor Jeff Feng received a \$17,000 grant from the Economic Development Administration (EDA), in collaboration with the University of Puerto Rico - Rio Piedras (UPR), for the project "Innovation and Commercialization for an Agile and Resilient Ecosystem (I+CARE) Program." Feng will deliver keynote lectures about innovation and business, plan and lead training workshops, and provide design and business mentorships to startups at the UPR Innovation Center. Feng also actively contributes research to the UH's Brain Center, focusing on design in the healthcare industry.

The Community Design Resource Center (CDRC) received a 2021 grant for "Driving Jensen" from the Local Initiatives Support Corporation. The combined goals of the project were expanding community involvement in transforming space in a way that meets their needs and visions; increasing access to decision makers and the decision-making process; and collectively identifying and advancing priority development projects resulting in a more just and equitable spatial practice.

Professor Daniel Jacobs partnered with Rice Architecture Assistant Professor Brittany Utting to win \$6,000 in seed funding from the Rice Design Alliance Houston Design Research Grant 2022. The duo won in the faculty category among seven submissions for their proposal, "HOUSTON-VARIATIONS," exploring typological variations that adapt to the city's ever-changing urban and ecological conditions. Their project will be published in *Cite* magazine and be presented at a Rice Architecture lecture.



### RESEARCH AND LAB STAFF POSITIONS ADDED

In 2021, Provost Short awarded the College a "Key Initiatives" award, opening a search for the new inaugural faculty Director of the Keeland Design Exploration Lab, a new Research Liaison Officer staff position, and two Graduate Assistant student positions to advance the Design/Build program.

The College's new Research Liaison Officer Maria Modelska is set to cultivate corporate relationships that will help advance the College's research through meaningful and impactful industry collaborations.

### A NON-PROFIT VENTURE TO GIVE STUDENTS EXPERIENCE

The College is preliminarily making plans to establish a 501(c)(3) organization focused on design/build. The new venture will greatly expand the College's ability to explore more substantial design/build opportunities for our students, including building speculative projects.

**TOP TO BOTTOM:** RENDERINGS AND DRAWINGS BY GRADUATE STUDENTS KIM SAO AND BLAKE WILCOX FOR A PROJECT THAT DEPENDED HEAVILY ON RESEARCH REFERENCES; TWO EXAMPLES OF PREVIOUS DESIGN/BUILD PROJECTS









# COLLEGE PERFORMANCE MEASURES

## TOTAL RESEARCH EXPENDITURES



## BACHELOR'S DEGREES AWARDED



## TOTAL ANNUAL GIVING (CASH BASIS)



## MASTER'S DEGREES AWARDED



## FIRST YEAR FTIC GRADUATION RATE

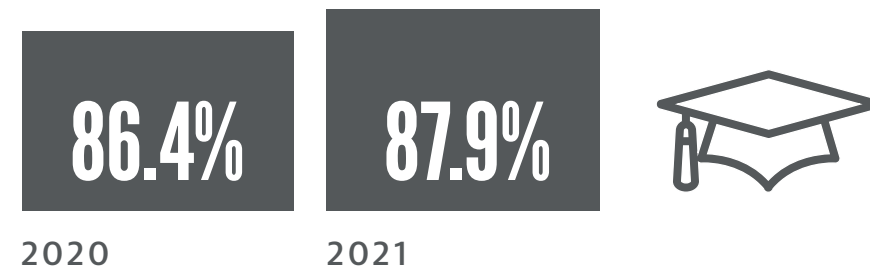

## JOURNAL PUBLICATIONS, CONFERENCE PRESENTATIONS & AWARDS

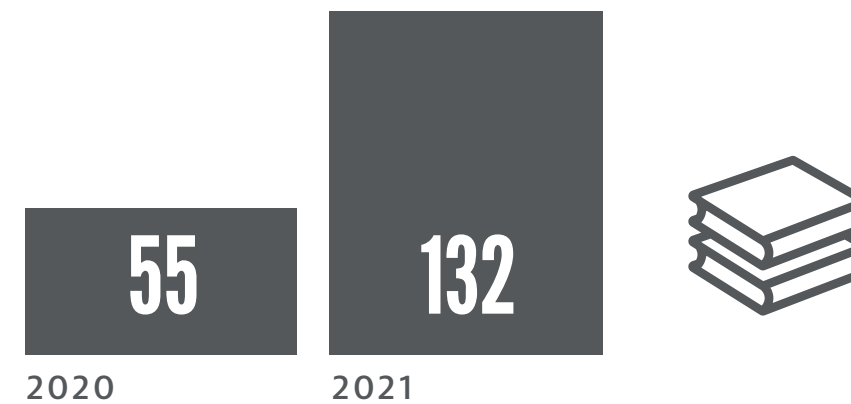

## SIX YEAR FTIC GRADUATION RATE

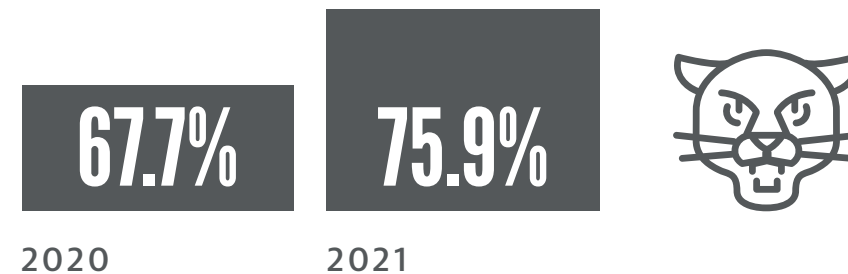

## PERCENTAGE OF UNDERGRADUATES COMPLETING 30 SCH







## STUDIO OF THE FUTURE CHARRETTE WEEK

THE SPRING 2022 SEMESTER KICKED OFF WITH AN ALL-COLLEGE ENDEAVOR FOCUSED ON THE *STUDIO OF THE FUTURE*, BRINGING TOGETHER STUDENTS AND FACULTY to shape architectural + design discourse and practice as the College prepares its next strategic plan. The week challenged normative thinking offering an opportunity to question, redefine, and reshape the studio culture of the College. As a result, students and faculty produced hundreds of proposals that were further reviewed by each studio as part of a non-traditional exhibition in the Mashburn Gallery. Each proposal is currently being consolidated and summarized for strategic planning. To the right is a summarized example of one provocation from the *Studio of the Future* initiative showing the resulting bold commitment and charrette recommendations.

### 4.1 Sustainability + Technology ECOLOGY IN THE CURRICULUM

**BOLD COMMITMENT:** Technical analysis of every design + every building demonstrably net zero or fail

To meet this bold commitment, the CoAD curriculum will integrate the theoretical and technical foundation for delivering high performance environments, buildings, and products. An updated curriculum will reflect the interdisciplinary necessity for solving humanities greatest challenge; integrate technology into studio projects at all levels; and result in installations, exhibits, and partnerships that demonstrate our commitment to a healthy and prosperous future.

*The following notes reflect feedback from the CoAD community of the charrette week ideas developed by students and faculty regarding curriculum:*

#### Charrette Recommendations:

- Education – passive, active systems– Integrated Tech and Studio with integrated projects and speakers
- Consultants – integrated rovers – diversified juries – always evaluated from all aspects
- Take tech earlier
- Model making and testing course
- True environmental and Site analysis course
- Ecological Case Studies / History of Ecological Architecture Course or overlay
- Ecology Integrated Design: Awareness Education / Solution education / Design Application
- More site visits – seeing construction
- Minor in sustainability / Ecological Architecture Certificate
- Super studio on technology
- Design build expansion
- Biomimicry course
- Construction documentation course – integrating construction and performance
- Energy Institute and Architecture and Energy in Houston with Oil and Gas – what does this mean?
- Hurricanes city/ Flood city/ Bayou city etc.
- Indigenous architecture and its response to climate
- Landscape Urbanism and Houston
- “After Comfort”
- Pollution into Materials (vs new materials)
- Adaptive reuse (vs Building new) Reassembling /Reversible design
- Legislative Action
- Do (stop drawing but do) – Required action thesis

## NAAB ACCREDITATION

IN MARCH 2022, THE COLLEGE WELCOMED THE NAAB ACCREDITATION TEAM FOR THEIR VIRTUAL VISIT. This visit included meetings with the College’s administration, academic directors, staff, students, and UH Provost Paula Myrick Short. After a thorough review, the College received an eight-year accreditation. There were some items identified by the NAAB team requiring additional assessment, and the College has up to three years to provide additional information to track and assess those items.

**ABOVE:** THERE ARE MANY COMPONENTS TO RECEIVING NAAB ACCREDITATION, INCLUDING DESIGN, HISTORY AND THEORY, AND RESEARCH INNOVATION



# LEADERSHIP COUNCIL

## NEW MEMBERS



### ROBERT DEL'VE, AIA

*Managing Director of Project Management, CBRE - Houston Office*

Robert Del'Ve is the Managing Director of Project Management (PJM) at CRBE in Houston, where he has been a leader in CBRE's Global Workplace Solutions business since 2016. Del'Ve is responsible for managing all facets of PJM business for the Houston market, including corporate interiors, investor-directed assets, and move management. He oversees a team of 12 project managers with a focus on growing the team and associated capabilities serving CBRE's clients in the greater Houston market. Previously, Del'Ve was Director of Strategic Sourcing and Global FM Lead for Global Workplace Solutions with a focus on California, Colorado, and Arizona. Before that, he was Senior Vice President for BMW where he led the American Design Studio's marketing, operations, product design, transportation design, and graphic design. Earlier in his career, Del'Ve held a leadership role with the Kohler Company overseeing the design production, showroom, and hospitality facilities. In addition to being a licensed architect, Del'Ve has a Master of Business Administration degree from California Lutheran University and a Bachelor of Business degree from Ferris State University.



### MICHAEL DESGUIN, AIA

*Senior Vice President of Conceptual Construction, Hines*

Michael Desguin, AIA currently leads the commercial development platform for the Hines Conceptual Construction Group. Spanning almost forty years, his career has been intensely focused on a model of collaboration with an emphasis on strengthening his connection to design leaders within the built environment and broadening his exposure to thought leaders beyond the built environment. Desguin's twenty-five years as an architect of record with Kendall/Heaton Associates followed by his last fourteen years with Hines, merges an architect's sensibilities with an owner's point of view, yielding a unique interdisciplinary perspective. Desguin is a registered architect with a Bachelor of Science in Architecture from Florida A&M University, 1982. He is a member of American Institute of Architects, Texas Society of Architects, and a former member of the Design Leadership Network.

### BENITO GUERRIER, M.ARCH. '91

*Executive Vice President, Kirksey Architecture*

Benito Guerrier is a multifaceted architect who has been practicing in Houston for more than 30 years. A native from Mexico City, where he obtained his Bachelor of Architecture also has a Master of Architecture from the University of Houston. For the past 26 years Benito has been at Kirksey Architecture and currently serves as Executive Vice President and Director of Government Projects. His projects range from community center, public schools and municipal building to large office building and civic plazas for local municipalities, the State and Federal Government. He is particularly passionate about historical buildings and his work has been recognized with multiple design and preservation awards. In 2020 Benito was named "Principal of the Year" by the SMPS for his leadership in the design and construction community of Houston. As a leader in our community, Benito has served on boards and commission of various organizations including Houston Hispanic Architects & Engineers, Houston Parks Board, Preservation Houston, Scenic Houston, Architectural Foundation and currently Chairs the Harris County Hispanic Cultural Heritage Commission.



### STEPHEN DRIVER

*Senior Vice President/Partner, Harvey Builders*

Stephen Driver, MBA '05 is a Partner with Harvey | Harvey-Cleary Builders. Our mission is creating relationships that lead to spaces where great things happen as a full-service general contractor. Driver has more than 23 years of construction experience, with the past 20 years for Harvey leading from concept to completion. Driver and his team, work with many leading design firms in the United States to craft beautiful interior environments from startups to Fortune 100 companies. In addition to earning his Master of Business Administration from the University of Houston in 2005, he graduated with a Bachelor of Science in Construction Science from Texas A&M University in 1997. Stephen is a Houstonian, growing up in Spring Branch, and currently residing in Katy, Texas with his wife, Marci, and two children. He personally enjoys supporting organizations centered around health, wellness and education, rooting on our local sports teams, and spending time with his family.







**DEAN STROMBOM, M.ARCH. '80**

*Principal, Gensler - Houston Office*

With a Gensler career spanning four decades and a portfolio of more than 50 million square feet, Dean leads the planning and design of corporate campuses, commercial office buildings, workplace interiors and mixed-use developments. He is the South-Central Region's strategic advisor to several of Gensler's practice areas, and a Houston office leader. A highly regarded workplace performance specialist and frequent speaker at industry events across the U.S., Dean leverages his unique blend of education in psychology, sociology and architecture to offer strategic real estate and design insight. He has authored many industry articles over the years and is co-author of *The Commercial Real Estate Revolution*. Dean is actively involved in the Houston chapters of professional organizations including NAIOP, ULI, HOLBA, CoreNet and AIA; and serves on the Board of the Houston Maritime Center. Dean graduated from the University of Houston's MArch program in 1980.

**CURRENT MEMBERS**

**MARILYN ARCHER, FIIDA, ASID,  
LEED AP - CHAIR**

*Principal and Founder, archer + eby design, and  
Retired Professional Services Firm Practice Area  
Leader and Principal, Gensler*

**ARTURO "ART" CHAVEZ, AIA, LEED AP,  
B.ARCH. '90**

*Senior Principal, Page*

**THOMAS E. "CHIP" CLARKE**

*President | Western U.S., Transwestern*

**JAMES E. FURR, FAIA**

*Managing Director @ Principal Emeritus,  
Gensler - Houston Office*

**EMILY HOWARD-WILSON, BFA '04**

*Senior Associate, Cushman and Wakefield*

**LAURI GOODMAN LAMPSON, BFA '88**

*President @ CEO, PDR*

**GARY LONGBOTHAM, BFA '73**

*Principal, J. Tyler Office Furniture @ Services*

**KEITH PROBYN**

*Vice President Real Estate Americas, Shell Oil Company*

**JOE WEBB, B.ARCH. '71**

*Founder and Principal, Webb Architects*

**LARRY E. WHALEY, P.E., ASCE FELLOW**

*Retired President, Haynes Whaley Associates, Inc.*





# HINES COLLEGE MOURNS PASSING OF FORMER DEAN

*College community reflects on the impact and legacy of Joe Mashburn '78*  
July 12, 2021



**ABOVE:** JOE MASHBURN

## THE UNIVERSITY OF HOUSTON GERALD D. HINES COLLEGE OF ARCHITECTURE AND DESIGN HAS LOST AN ALUMNUS, FORMER DEAN, AND FRIEND.

**JOSEPH LAING MASHBURN,  
FAIA '78** – known as “Joe” to his students and colleagues – passed away on over the weekend from pancreatic cancer at the age of 80. Joe served as dean of the Hines College from August 1998 to December 2009.

Joe came to the University of Houston as an engineering student but quickly discovered his love for architecture. He graduated from the UH architecture program in 1978 with a Bachelor of Architecture and earned his Master of Architecture at Texas A&M University in 1982. Joe went on to work as an assistant professor and the graduate design coordinator at Texas A&M from 1982-88 until accepting a position at Virginia Tech as a full professor in 1989. From 1993-94, he served as the architecture department head at the Curtin University of Technology in Perth, Australia.

While teaching at Virginia Tech, Joe received an unexpected call asking him to consider applying for the open Hines College dean position. At first, Joe and his wife, Julia, laughed because a deanship was nothing Joe had ever even considered.

When Joe arrived at the Hines College in 1998, he found a College very different from the institution he had graduated from twenty years before. Student enrollment had drastically increased to around 500 students, and the College had moved to the current Philip Johnson building dedicated in 1986. The College was also grappling with accreditation problems and a comprehensive design program that did not exist. Joe was determined to transform these challenges into strengths and ultimately established the College as a leader in Texas within these areas.

“Joe Mashburn was passionate about design: from architecture to objects, the simpler, the better,” said Lannis Kirkland, former associate dean at the Hines College. “I was fortunate to

know Joe for about 50 years, serve as associate dean while he was dean, and travel with him and students in Italy. Joe rarely had a negative thing to say about anyone.”

While at Virginia Tech, the architecture school started an industrial design program, and it opened Joe’s eyes to the value the discipline contributed to the school. The program brought a hands-on approach challenging the architecture program to think differently about materials and fabrication.

“When planning for the College’s industrial design program, Joe toured Texas and engaged with design professionals, both in corporate offices and design consulting firms,” shared industrial design professor Mark Kimbrough. “I met Joe in Austin, where I had my product development firm at that time. It became clear Joe had a vision – one that included bringing industrial design education to a part of the country with a burgeoning technology and manufacturing industry.”

In 2003, five years into his deanship at the College, Joe established the new industrial design program, the only one of its kind in a four-state region at the time. He hired EunSook Kwon as the program’s founding director, and 18 years later, the program is an award-winning leader in the United States and the global community.

“Joe hired me for a special mission — to establish the first industrial design degree program in the state of Texas,” shared Kwon. “Without his always positive, encouraging comments and big smiles, the program would not be what it is today. His philosophy of design education can be highlighted in his words, ‘I will support whatever you do for the program, but the final outcome should be undeniably beautiful.’”

One of Joe’s most significant accomplishments was creating the Burdette Keeland, Jr. Design Exploration Lab, dedicated in 2004. The Keeland Lab still operates as one of the largest higher education fabrication facilities in the country. It was developed as a place where students could see their ideas come to fruition.

“Once ensconced in his role as dean, Joe proffered an unlikely vision,” said Patrick Peters, architecture professor and coordinator of the graduate design/build studio. “Where most saw a disheveled and underutilized ex-military shed deserving of an imminent demolition, Joe saw the promise of a new and uncommon

resource – a much-desired expansive shop equipping architecture and industrial design students to meet the challenges of 1:1 fabrication.”

Joe’s experience as an architecture student at the University of Houston in the 1960s and 70s, when physical making was a call to action and physical actions of all sorts were a means of advancing architecture and sociological ideas, inspired his audacious vision for the Keeland Lab.

“Upon the completion of the Keeland Lab, the former utilitarian structure was awarded a Texas Society of Architects design award, a first for a UH campus building,” shared Peters. “Since its opening, students have benefited from its impact, but perhaps none more than those of the Graduate Design/Build Studio. For more than 30 years, the program has allowed students to measure the quality of their ideas against the rigorous standard imposed by full-scale reality.”

In addition to his role as dean, Joe also taught an introductory course for architecture and industrial design first-year students and prospective students considering changing their major. Through this, he shared the world of architecture with young minds and influenced future generations of architects and designers.

“One of my earliest and most enduring memories of Joe was his

genuine commitment to supporting students. Soon after he became dean, he met with me to ask about them, which signaled to me then, as it does now, how much students meant to Joe,” said assistant dean Trang Phan. “For many thousands of students whose lives Joe touched as their dean and later as their instructor as well, his sense of humanity and insistence on the human touch made all the difference in their personal and professional lives.”

Since learning of his passing, many alumni and friends have taken to social media, sharing their sympathies and acknowledging Joe’s impact on their academic and professional careers.

“Joe came to our College with the vision and the drive to strategically move it forward to the next level,” shared current Hines College dean Patricia Belton Oliver, FAIA. “His influence is still visible and will not be forgotten by our alumni, faculty, and staff. The Hines College today would look very different had it not been for Joe’s passion and leadership.”

“Joe was particularly proud and grateful for his undergraduate education at UH,” shared Kirkland. “One of the last conversations I had with him, he expressed that he would not have traded his UH architecture experience for ‘any school on the planet.’” —*Stephen Schad*



# HINES COLLEGE CELEBRATES HISTORIC 75<sup>TH</sup> ANNIVERSARY

*Gala event remembers Gerald D. Hines and honors the Hines Family*  
October 15, 2021

THE UNIVERSITY OF HOUSTON GERALD D. HINES COLLEGE OF ARCHITECTURE AND DESIGN CELEBRATED ITS MILESTONE 75<sup>TH</sup> ANNIVERSARY WITH A HISTORIC GALA EVENT on Saturday, October 9th, chaired by alumnus and Senior Principal at Page/ Arturo Chavez '90 and driven by the College's Leadership Council. Hines College alumni, industry partners, and friends gathered to remember its namesake, the late Gerald D. Hines, and honor the Hines Family. The event took place at the iconic Philip Johnson-designed architecture building on the UH campus after being postponed one year due to the ongoing COVID-19 pandemic.

Headlined by gala diamond sponsors Aramco, Hines, and Page/, the Hines College raised nearly \$450,000 supporting student scholarships and the new Advanced Media Technology Lab, currently in phase II of fundraising. The silent auction featured iconic and unique items, including Gerald D. Hines' personal slide rule, donated specifically for

**OPPOSITE PAGE:** THE HINES COLLEGE COMMUNITY AND DONORS CELEBRATE OUTSIDE OF THE KEELAND LAB BEFORE HEADING INTO THE COLLEGE BUILDING TO CONTINUE THE FESTIVITIES







**OPPOSITE PAGE, TOP TO BOTTOM:** HOUSTON CITY COUNCILMAN DAVID ROBINSON PRESENTS THE COLLEGE WITH A PROCLAMATION DECLARING OCTOBER 9, 2021 AS THE UNIVERSITY OF HOUSTON GERALD D. HINES COLLEGE OF ARCHITECTURE AND DESIGN DAY; DEAN PATRICIA BELTON OLIVER IN THE COLLEGE ATRIUM AS A SECOND LINE BRASS BAND PLAYS AND GUESTS ADMIRE AIRSCAPES #1



the event by Hines. Houston firm Kendall/Heaton bid the highest for the slide rule, winning with an impressive \$50,000 bid.

Kendall/Heaton has worked closely with Hines for decades, developing exceptional architecture for the organization. The firm established the Bill Kendall Memorial Endowed Professorship of Advanced Technologies at the Hines College in 2018. Hines donated \$500,000 to the professorship in 2019, pushing the endowment to over \$1 million. Andrew Kudless, director of the Construction Robotics and Fabrication Technology (CRAFT) Lab and coordinator of design media at the College, currently holds the Kendall professorship.

The event marked a perfect opportunity to look back on how the Hines College has flourished since Gerald D. Hines made his game-changing \$7 million gift in 1997, shortly after the College's 50th anniversary. Grandson Matthew Hines represented the Hines Family, reflecting on how his "Opah" impacted the College in the last 25 years and supported young architects. Chairman and CEO Jeff Hines and his daughter Laura Hines-Pierce, Senior Managing Director,

were unable to attend but provided inspiring video messages reflecting on Mr. Hines' legacy.

During the program, Dean Patricia Belton Oliver, FAIA, DPACSA, welcomed Houston City Councilman David Robinson to the stage to present the College with a proclamation from the City of Houston declaring October 9, 2021, as *University of Houston Gerald D. Hines College of Architecture and Design Day*. Gala chair Arturo Chavez '90 reflected on the importance of celebrating this special anniversary and the need for the community to continue supporting the Hines College. Dean Oliver also introduced eleven students ambassadors attending the gala, sharing their inspirational stories and paths to the College. The program closed out a video containing messages from Jeff Hines and Laura Hines-Pierce and interviews from alumni and industry partners looking back on Gerald D. Hines' impact.

After the program, guests followed a lively second-line brass band into the architecture building's atrium. Student work was on display throughout the building's studios for guests to peruse, and the Airscapes #1 installation was unveiled, one of the largest inflatables ever developed.

Hines College architecture professors Rafael Beneytez-Duran and Peter Jay Zweig developed the much-anticipated installation. In 1986, inspired by the project *The House of Education* (1773) of Claude Nicholas Ledoux, Philip Johnson and John Burgee reassembled the new UH architecture building around an invented atrium to collect the knowledge and new ideas of architecture into a historical internal court.

Airscapes #1, a dynamic pneumatic structure, challenges the values of the past by using the ecology of air, the turbulence of our times, the rising temperature of those viewing and interacting with the Airscape, which is tempered by the ever-changing surrounding atmosphere. The floating structure of 380,000 cubic feet allows one's mind to move freely within this reconceived space of the *House of Education*.

As the evening came to a close, the College presented guests with a 75th anniversary book produced by the Hines College. The publication highlights how the College's programming has grown since its 50th anniversary in 1995. —Stephen Schad



# ARCHITECTURE

## UNDER THE LEADERSHIP OF DIRECTOR OF GRADUATE STUDIES GAIL PETER BORDEN AND DIRECTOR OF UNDERGRADUATE

**ARCHITECTURE RAFAEL BENEYTEZ-DURÁN**, the graduate and undergraduate architecture programs are flourishing and promoting exciting new views educating students in the discipline and profession of architecture with awareness of global dynamic, international engagement, and local care. Andrew Kudless, Kendall Endowed Professor of Design Technologies and coordinator of Design Media, has developed ways of integrating Design Media into students' education so they are empowered with extremely well-calibrated tools to operate design in the digitalization of our era.

## NEW HISTORY, THEORY, AND CRITICISM FACULTY

Deepa Ramaswamy joined the College in fall 2021 as the new tenure-track historian. The College also welcome its second emerging scholar fellow Tania Gutiérrez-Monroy.



LEFT TO RIGHT: DEEPA RAMASWAMY AND TANIA GUTIÉRREZ-MONROY

## PROSPECTUS

Director of Undergraduate Architecture Rafael Beneytez-Durán has published the College's first *Prospectus* giving a detailed look into the Undergraduate Architecture curriculum and student work produced through the program.



### VIEW A DIGITAL COPY

SCAN THIS CODE TO FLIP THROUGH  
THE *PROSPECTUS 2020-21*

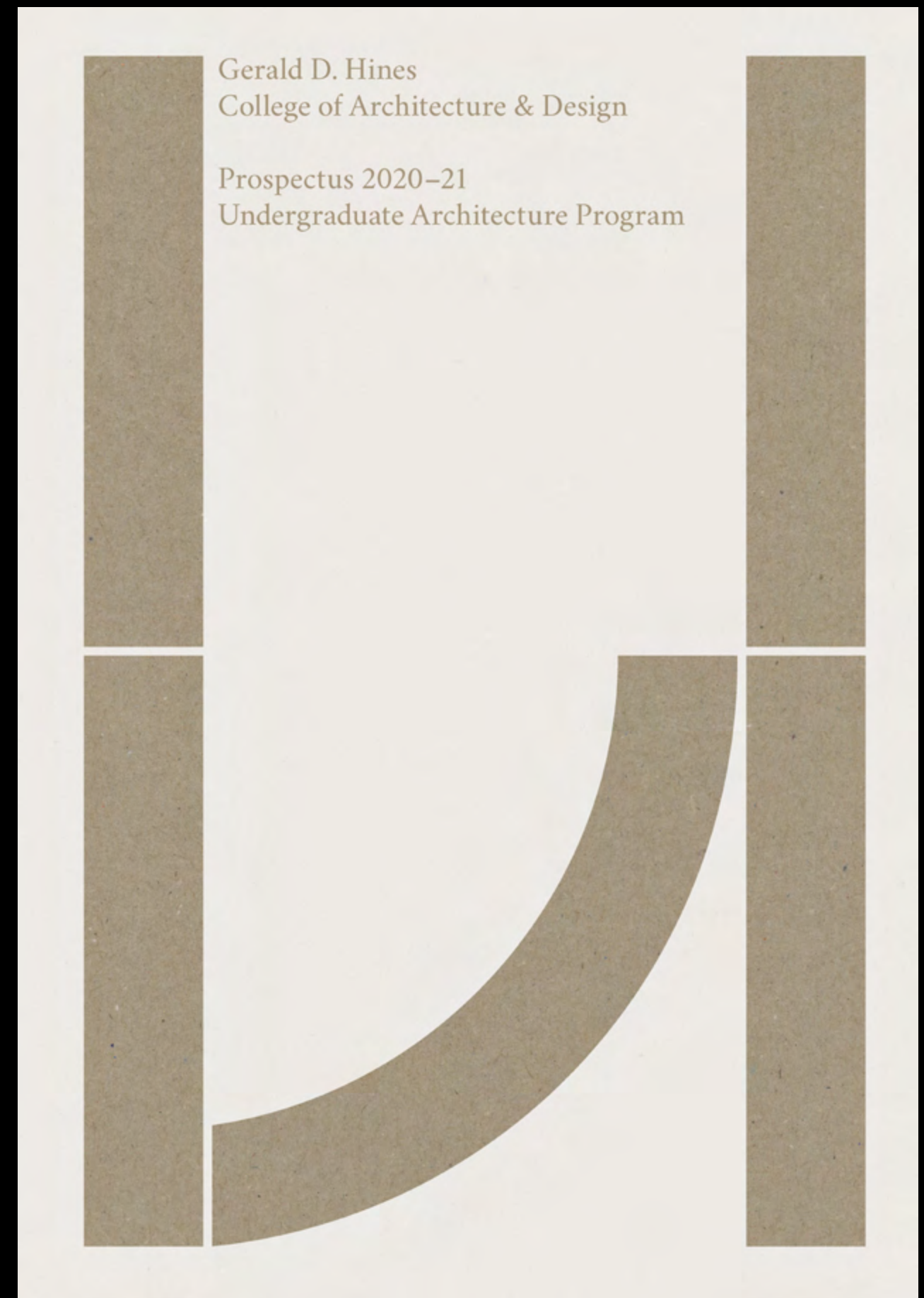







# ARCHITECTURE STORIES

## A VISION FOR THRIVING, SUSTAINABLE GLOBAL COMMUNITIES

UH Architecture Students Present 'City of Refugees' with World-Renowned Ai Weiwei at Aedes Exhibition in Germany  
October 2020

### AI WEIWEI'S PATH FROM ARTIST TO ONE OF THE MOST INFLUENTIAL SOCIAL ACTIVISTS OF OUR TIME HAS BEEN PAVED IN PERSONAL EXPERIENCE.

From growing up in a Chinese labor camp to later being exiled with his family, Ai Weiwei lived in harsh conditions until a teenager. Living conditions of refugees around the globe and themes of human ingenuity and resilience despite the most extreme circumstances were at the center of a tandem interactive exhibit with Ai Weiwei and the University of Houston Gerald D. Hines College of Architecture and Design at the prestigious Aedes Architecture Forum in Berlin, Germany, in October 2020.

*City of Refugees*, an exhibition presented by UH architecture students, and *Purgatory*, the art installation by Ai Weiwei, together turned the spotlight to challenges faced by refugees and offered

solutions to building self-sustaining and thriving refugee communities across the globe.

"In the camps at Bangladesh the houses are lightboxes, there is pouring rain, but inside it is not hot and it stays dry," said Ai Weiwei, about the living conditions refugees experience. "To think these odd buildings with no cost and made of bamboo, much of it built by non-architects, is created by people with waste materials and everything is so intelligent."

### BUILDING A CITY OF REFUGEES

The problems embodied by Ai Weiwei's *Purgatory* inspired *City of Refugees* and a three-year intensive sequence of design studios led by Hines College professors Peter Jay Zweig and Gail Peter Borden, both fellows of the American Institute of Architects (AIA). The project centered on developing a provocative

approach to proposing four prototypical refugee cities of varying sizes on four continents, ranging from 50,000 to 500,000 people.

"I fell in love with the idea of a city for people that have been impacted by problems in their own countries," said UH former architecture Carlos Soto '20, who had a personal connection to the project. "When this assignment began in 2017, people from my home country of Venezuela were leaving on foot to escape to Colombia. They were stuck in limbo between their drastically changing homeland and a place they were not used to."

*City of Refugees* reinterpreted Thomas More's 1516 book *Utopia*, in that it represented a place transcending the fate of those who have been displaced from their homeland. The concept of the refugee city developed by the UH team was built upon universal



architectural principles and local traditions openly welcoming migrants looking for a place to be free and act independently.

"The blending of local and social customs with the imported influx of refugees creates an environment that is committed to the idea of a 'pledge' given upon arrival to the city, for social acceptance through community volunteer programs, self-empowerment, education, shared

communal kitchens and work spaces," said Zweig.

### FOUR CITIES

As United Nations-sponsored free economic zones, the four proposed locations in *City of Refugees* created a platform for a new multi-ethnic society based upon justice, tolerance, and an economically viable net-zero environment. The cities were intended to embody world citizenship with an emphasis on education, health and

**ABOVE, CLOCKWISE FROM TOP LEFT:** RENDERINGS OF BRIDGE CITY, GRADIENT CITY, SWITCHBACK CITY, AND UPCYCLE CITY



“The City of Refugees is a proposition to solve a problem that exists not only for refugees, but as a possible solution to climate change ...”



responsibility – a place where people could come to create their own lives.

- BRIDGE CITY (South America) – located on the Rio Santiago in Ecuador near the Peruvian border just south of the equator
- gRADIANT CITY (Africa) – located on the east side of the Democratic Republic of Congo (DRC), on the edge of Lake Edward and on the border between DRC and Uganda
- SWITCHBACK CITY (Southeast Europe) – located on the border

between Serbia and Romania along the Danube River near the city of Tekija, Serbia

- UPCYCLE CITY (South Asia) – located on the Coast of Bengal in Bangladesh near the border to Myanmar

In funding the establishment of these cities, students researched and analyzed the annual United States military defense spending, amounting to \$700 billion. They found that one-quarter of one percent of the military budget could easily fund a city of refugees.

“A geometric infrastructure, partnered with indigenous material systems allowing for regional contextualism empowers residents to individually infill, develop, and complete the urban fabric,” said Borden, describing the impact of urban innovation on the project. “The result is an innovative, sustainable, evolutionary, and interconnected community-based city.”

While the exhibition featured a 20-foot three-dimensional model, it took on an immersive format extending beyond the physical models and drawings, welcoming participants to

enter into an augmented reality that coexisted with the physical exhibition.

“We were excited to exhibit again at Aedes as part of Aedes’ 40th anniversary and with the highly respected and influential international artist Ai Weiwei,” said Patricia Belton Oliver, FAIA, dean of the Hines College, “The work of our students and faculty on this exhibition was timely and the blending of traditional models and drawings with augmented reality offered an extraordinary experience. My hope is their investigation and proposals inspired change and served

as a catalyst for action supporting refugees throughout the world.”

*City of Refugees* was the Hines College’s third international endeavor since 2014, supported by the generosity of the late Gerald D. Hines. The exhibition was on display at the Aedes Architecture Forum, alongside Ai Weiwei’s *Purgatory*, October 30, 2020 through January 7, 2021.

—Stephen Schad and Sara Tubbs

**ABOVE:** THE CITY OF REFUGEES SHOW AT THE AEDES EXHIBITION, BERLIN, 2020



## STUDENT HONORED WITH ACSA AWARD FOR “THE SKY HOUSE”

Home design highlights the timeless relationship of humanity and nature  
October 15, 2020

**GERALD D. HINES COLLEGE OF ARCHITECTURE AND DESIGN ALUMNUS CARLOS SOTO '20** recently received an award from the Association of Collegiate Schools of Architecture (ACSA) 2020 Housing Competition for his project *The Sky House*, an endeavor undertaken for a studio project during his last semester as a student. Soto’s work was recognized with an Honorable Mention from the prestigious competition.

The project was born from Professor Peter Zweig’s studio assignment to design a home of the 21st century that would go beyond time and be relevant here and now. Soto sought to create a house that would follow the alignment of the cosmos and create spaces honoring light, time, and space.

“When I was little, I wanted to become a pilot, and then an astronaut,” said Soto. “I always loved looking up at the sky, the stars, and constellations.”

Soto based the concept of his house design under the premise that the client was a retired couple who previously served as NASA astronauts. The couple had spent their careers dedicated to space and wanted a home that would reconnect them with the universe, set in the reflective and calming desert of New Mexico.

The house is divided between two focal spaces – the day room (or sun/living room) and the night room (or dining room). The day room exterior walls are slanted to block the sun at

its highest points during the summer. The room’s roof comes up and tilts at an angle so those in the room can enjoy the blue sky, benefit from natural light, but also be protected from direct sunlight.

The night room is smaller in scale and creates a frame at night so those inside can view the moon and stars. In the evening, the primary bedroom is oriented in a way that facilitates the unique opportunity to experience the winter solstice sunset.

While the stunning landscape makes up for the limited resources available to life in the desert, the design needed to compensate for these harsh desert conditions. Soto designed the home with a pool

storing rainwater and passing the water through a filtration system. The pool then serves as a source of hydration and also cools the house by passing the breezes over the pool. During winter, the home is naturally heated with the combination of its high openings, the low altitude of the sun, and the dark walls from the sun and moon rooms.

The strategic design of Soto’s Sky House is exquisite and brings together the timeless relationship between humanity and nature.

“The project transcends time,” shared Soto. “If you looked at the same project 20 years ago or 20 years from now, it can still happen and have equal impact.” —*Stephen Schad*

**OPPOSITE PAGE:** A RENDERING OF THE SKY HOUSE COURTYARD

**ABOVE:** AN EXTERIOR RENDERING OF THE PROJECT; SOTO DREW INSPIRATION FROM THE STARS TO DESIGN THE SKY HOUSE





## HINES COLLEGE STUDENTS HELP BUILD SCHOOL IN HONDURAS

Students' efforts make new school building a reality  
January 8, 2021



**TOP TO BOTTOM:** PROFESSOR DIJANA HANDANOVIC AND AWTY SCHOOL STUDENTS WORKING TOGETHER; STUDENTS IN THE NEW HONDURAS SCHOOL BUILDING

**GERALD D. HINES COLLEGE OF ARCHITECTURE AND DESIGN PROFESSOR DIJANA HANDANOVIC** and seven undergraduate Architecture students joined forces with Houston's Awty International School and non-profit organization Schools for Children of the World (SCW) to raise money and build a new school in a rural Buenos Aires village, fifteen miles from Comayagua, Honduras.

Professor Handanovic and the students – Sarah Neiman, Morgan Mendenhall, Chris Nguyen, Sarah White, Andrew Medina, Edgar Castillo, and Steven Griffin – built a physical model of the Honduras school building envisioned by SCW. The students also produced several graphic representations, which were initially scheduled to be displayed at the annual Awty International Festival before the event's cancelation due to COVID-19.

"It was nice to see our students interact and build a relationship with The Awty School students," said Handanovic. "They were enthusiastic about this project and doing something good for the community in Honduras."

SCW and Awty International students raised more than \$23,000, with the total cost of construction for the project estimated to be \$22,000.

Hines College undergraduate students initially planned to travel to Honduras for a week with Awty students this past summer to help build the school; however, due to the unprecedented pandemic, they could not see the project come to fruition in person. While the upcoming year is uncertain, everyone involved desires to continue involvement in projects impacting the global community, such as this one.

"I am proud of the relationship coming out of this project with the Awty School," said Handanovic. "There was even talk about starting a program with Awty International upper-level students and University of Houston undergraduate students."

The Hines College of Architecture and Design is known for its work in the community, including locally with its Community Design Resource Center and other partnerships worldwide.

—Destiny Vaquera

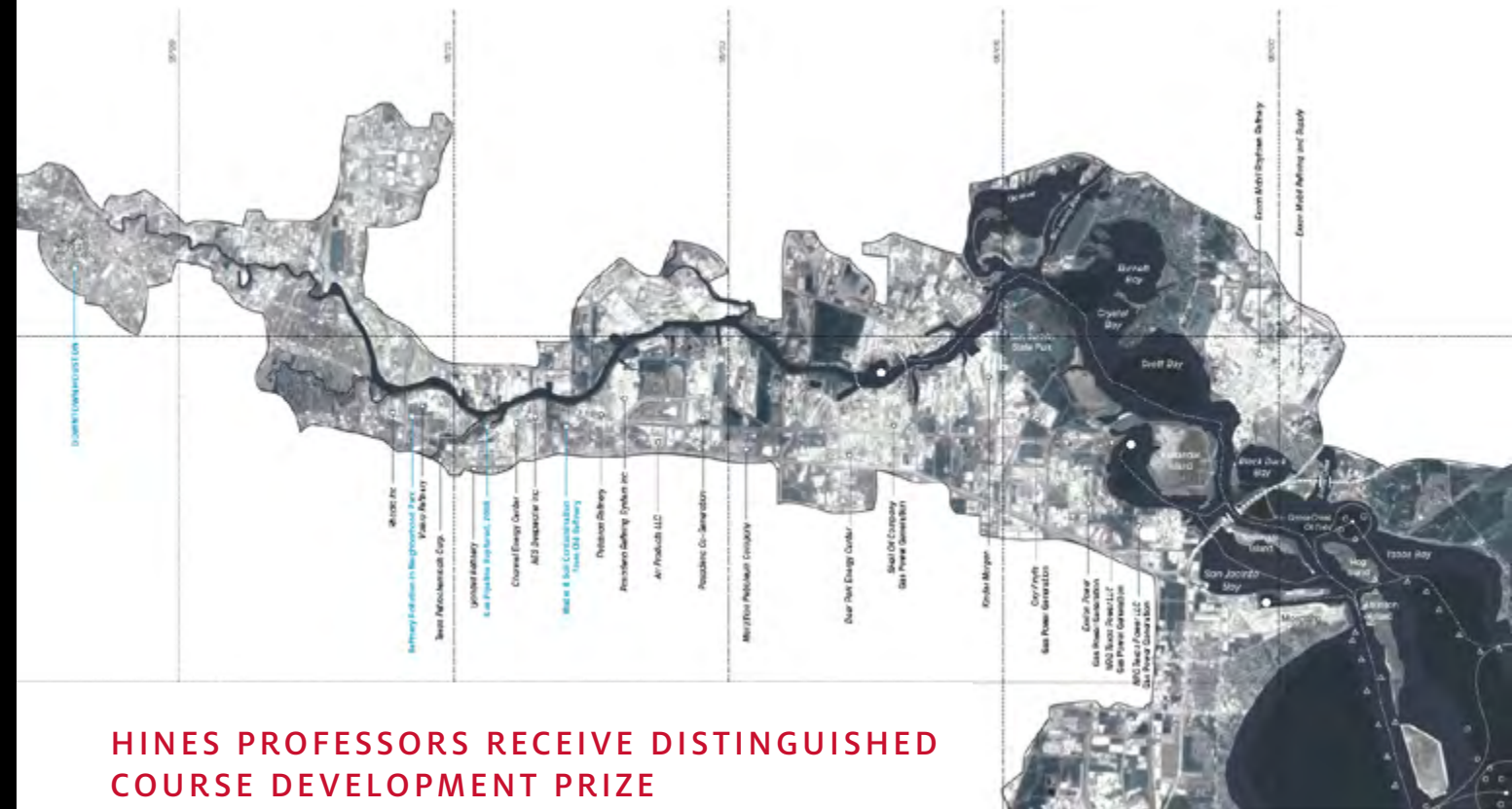

## HINES PROFESSORS RECEIVE DISTINGUISHED COURSE DEVELOPMENT PRIZE

Convergence of interests explores issues of environmental justice and inequity  
January 26, 2021

**GERALD D. HINES COLLEGE OF ARCHITECTURE AND DESIGN PROFESSORS MATTHEW JOHNSON AND MICHAEL KUBO** have been selected for the 2021 Course Development Prize in Architecture, Climate Change, and Society. The prize is awarded through a partnership of the Association of Collegiate Schools of Architecture (ACSA) and the Columbia University Temple Hoyne Buell Center for the Study of American Architecture. Johnson and Kubo's proposal was one of five chosen from among 70 submissions across the United States.

In 2017, Johnson and his students examined the influence of

petrochemical landscapes as part of the Houston: Genetic City exhibition premiering at the Aedes Architecture Forum in Berlin, Germany. The accompanying book was released last year. Johnson is invested in the intersection of landscape, urbanism, and territory with energy and carbon culture, complimenting Kubo's interests in the historical archaeology of the petrochemical industry and of Houston and the Gulf, an epicenter in the United States of a long century of global petroculture.

Discussions surrounding their shared interests in the petrochemical culture and its influence on Houston began two years ago.

**ABOVE:** A MAP OF PETROCHEMICAL REFINERIES ALONG THE HOUSTON SHIP CHANNEL



"Both of us feel quite strongly that Hines College should really be a center for this kind of research on the environment of the Gulf and the Gulf Coast," shared Kubo.

"For a long time, Michael and I have been interested in the impact energy has on the landscape," said Johnson, "You can really see it in the Houston Ship Channel. If you drive out there, it is a kind of drastic incursion of industry on a fairly fragile landscape."

As conversations grew between the two professors, the inaugural Buell Prize was announced in 2019. Both professors thought the prize was an ideal opportunity to boost establishing potential course opportunities at the Hines College.

"We were interested in looking at the Gulf Coast as a built environment and the ways in which the petrochemical industry has impacted it," said Johnson. "Eventually, this would change in the future as those industries evolved and as renewables and other carbon-neutral sources of energy come online."

Their research's conversion also provides a chance to form a new path in the curriculum as the College builds its History, Theory, and Criticism (HTC) program.

"We were already talking about bridging the gap between studio and history, theory, and criticism," said Kubo. "We had discussed hybrid formats across a studio and research seminar, study that would be site-based, and ways of creating specific opportunities for longer-term research initiatives within the curriculum."

This year's winning proposal combined Johnson and Kubo's shared interests in the impacts of petrochemical culture with a focus on environmental justice. The proposal suggests looking at the community impacts resulting from petrochemical development occurring on the Gulf Coast, including the many fenceline communities bordering industry.

"Both of us feel quite strongly that Hines College should really be a center for this kind of research on the environment of the Gulf and the Gulf Coast," shared Kubo. "All the implications of addressing issues of precarity, environmental justice, and inequity have transformative potential in these research projects."

Students are also likely to champion these efforts to create coursework geared toward social equity. "I think questions of climate change and environmental justice are much more central to our student's thinking than a lot of our faculty realize," said Johnson. "I found that whenever we teach a course on environmental questions, students are really engaged."

Johnson and Kubo plan to develop a vertical course over the next year where the studio and HTC components will run parallel. As part of their award, the professors received an \$8,000 prize to help jumpstart their plans and will present their proposal at the ACSA's 109th Annual Meeting on March 24-26, 2021. —*Stephen Schad*

## KYROPOULOU RECEIVES NEW FACULTY RESEARCH AWARD

*Professor proposes research highlighting the parametric design of outdoor adaptive classroom space*

February 8, 2021

**THE UNIVERSITY OF HOUSTON RECENTLY SELECTED GERALD D. HINES COLLEGE OF ARCHITECTURE AND DESIGN PROFESSOR MILI KYROPOULOU TO RECEIVE A NEW FACULTY RESEARCH PROGRAM AWARD.**

She plans to develop and test an environmental performance-based computational workflow to supporting the parametric design of an outdoor adaptive classroom space.

The University of Houston's New Faculty Research Program grants up to \$6,000 to individual faculty members in an effort to cultivate and support scholarly research. Kyropoulou hopes to use this grant for assistance with student engagement, external collaborations, and publications, as well as the use of specialized computational software.

"I look forward to seeing the extent to which the proposal will be able to be generalized through proper scalability and variation," said Kyropoulou. "This application may act as an educational motif encouraging people to spend more time outdoors and reevaluate their perception of thermal comfort."

Her research plans to evaluate an adaptable, self-supported pavilion in Houston, Texas. Growth patterns, density, movable components, and other properties will be optimized and tested against comfort metrics. The nature of Kyropoulou's proposed project creates an example of performative design grounded in evidence supported by design techniques and scientific input.

"Although I have worked for grants in the past, I am excited that this will be my first time working as the primary investigator," shared Kyropoulou. "This grant allows me to pursue my research interest within the institution."

Kyropoulou is the co-founder of MEDiAM Design Collaborative and assistant professor of architecture design and environmental systems at the Hines College, as of fall 2020. Before becoming a full-time faculty member at the College, Kyropoulou taught as an adjunct professor. She is also involved in the International Building Performance Simulation Association (IBPSA) Houston chapter, recently organizing its 2020 Performance Huddle conference.

—*Destiny Vaquera*



**ABOVE:** MILI KYROPOULOU



AT RIGHT: ELEVATION DRAWINGS OF THE "LEWIS CENTER"

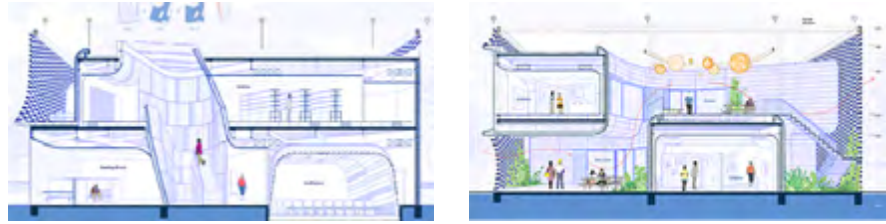

## ARCHITECTURE STUDENTS WIN AIA FORT WORTH MERIT AWARD FOR "LEWIS CENTER"

Project highlights late congressman John Lewis and the Civil Rights Movement  
March 2, 2021

**UNIVERSITY OF HOUSTON GERALD D. HINES COLLEGE OF ARCHITECTURE AND DESIGN STUDENTS CALEB MATHESON AND DARCI MCGEE** recently received the Merit Award from the AIA Fort Worth Excellence in Architecture Student Design Awards for their project *Lewis Center*, a tribute to the life and work of the late congressman John Lewis.

The project was born from Professor Emily Moore's studio assignment to design a social justice center that would revitalize a community. The Lewis Center orients itself towards serving surrounding communities of the Sweet Auburn Historic District in Atlanta, Georgia – a significant historical region containing markers and monuments from the Civil Rights Movement.

Matheson and McGee sought to create a space celebrating John Lewis and perpetuating his mission of getting into "good trouble" for the sake of social justice. The word "dreams" as a metaphor, packed with

imagery and having significance within the civil rights movement, was the *Lewis Center's* inspiration.

"Our goal for the building was for it to function as the dream of the community," said Matheson. "We wanted to help the community crystalize new ways of expressing itself."

The *Lewis Center* draws on the metaphor of pushing boundaries through the progressive interior and against the conventional exterior. The project's exterior Flexbrick material and metal panels contrast one another to continue developing the local area's architecture. Simultaneously, the interior incorporates exhibits of local artists, providing a space for expression and social gathering for the community.

"I believe the flexible sunscreen facade helped elevate our project," shared McGee. "Our vision was to create a seamless social connection between the building and the community." —*Destiny Vasquez*

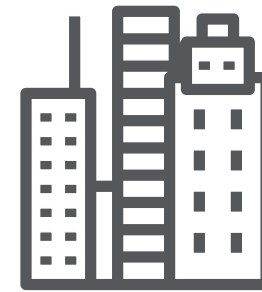

"The Directed Program Grant will contribute to developing our HTC program, and particularly to creating new opportunities for students and faculty ..."

## KUBO AWARDED HOUSTON ENDOWMENT DIRECTED PROGRAM GRANT

Professor proposes research highlighting concepts of time and lateness within the history of architecture

March 9, 2021

**GERALD D. HINES COLLEGE OF ARCHITECTURE AND DESIGN PROFESSOR MICHAEL KUBO** was selected this year to receive a grant from the Houston Endowment. He plans to engage in theoretical and historical research on concepts of time and lateness within the history of architecture and urbanism in order to promote new conceptual frameworks and methodologies for contemporary processes of adaptive reuse, maintenance, preservation, and sustainable design in the built environment.

The Houston Endowment is committed to advancing the equity of opportunity for Houstonians and advancing research within the city of Houston.

"I look forward to seeing how this project can lead to new history, theory, and criticism (HTC) courses as generators for broader research initiatives at the Hines College," said Kubo. "The Directed Program Grant will contribute to developing our HTC program, and particularly to creating new opportunities for students and faculty to work together in engaging key historical and theoretical questions regarding the design of the built environment."

Kubo wants to investigate the importance of periodizing concepts in architecture and culture – including late style, late capitalism, late modernism, belatedness, nostalgia, hauntology, and retro-futures.

"This project forms part of a broader collaborative initiative around questions of time and temporality in architecture," shared Kubo. "Houston Endowment's support allows us the opportunity to develop different aspects of this project within the College, particularly surrounding Houston's own history and futures".

Kubo is an author and assistant professor of architectural history, theory, and criticism at the Hines College, currently serving as the program coordinator for HTC at the graduate and undergraduate levels. This year he and associate professor Matt Johnson also received the *2021 Course Development Prize in Architecture, Climate Change, and Society* from the Association of Collegiate Schools of Architecture (ACSA) and the Temple Hoyne Buell Center for the Study of American Architecture at Columbia University.

—*Destiny Vasquez*



**PROFESSOR KUBO RECEIVES 2021 SAH EXHIBITION CATALOGUE AWARD**

Book highlighting the architecture and urbanism of the Pittsburgh Renaissance recognized by the Society of Architectural Historians

April 16, 2021

**LAST NIGHT, THE SOCIETY OF ARCHITECTURAL HISTORIANS (SAH) AWARDED HINES COLLEGE PROFESSOR MICHAEL KUBO** with the 2021 Exhibition Catalogue Award for his book *Imagining the Modern: Architecture and Urbanism of the Pittsburgh Renaissance*, co-authored with Chris Grimley and Rami el Samahy and published by The Monacelli Press in 2019.

The SAH award recognizes and encourages excellence in publications of architectural history exhibitions. It also acknowledges catalogues that address historical and critical questions through documentation and artifacts for a diversified audience, becoming distinctive models for the expression of scholarship in architectural history.

“It’s an honor to be a part of the fantastic lineage of books that have received the Exhibition Catalogue Award,” said Michael Kubo. “We especially appreciate SAH’s recognition of our efforts to create a work of historical scholarship and



advocacy that can have a life beyond the exhibition itself.”

*Imagining the Modern* originated from an exhibition of the same name that revisited the contentious legacy of Pittsburgh’s urban renewal era, curated by Kubo, Grimley, and el Samahy at the Heinz Architectural Center (HAC), Carnegie Museum of Art in Pittsburgh in 2015-2016. The exhibition formed part of HAC Lab Pittsburgh, the first in a series of initiatives at the Heinz Architectural Center dedicated to examining and presenting the history of architecture, planning, and urban development in Pittsburgh and the region.

In *Imagining the Modern*, Kubo, el Samahy, and Grimley explore the modern architecture and urbanism of the Pittsburgh Renaissance, an ambitious era of urban revitalization

in the 1950s and ‘60s that transformed Pittsburgh and became a model for other U.S. cities. The book provides a complex view of the city’s post-World War II development through documentation, photographs, essays, analytical drawings, and interviews with protagonists and participants in the city’s transformation in this period.

“The book tries to reassess the Pittsburgh Renaissance beyond the almost exclusively negative narratives that have framed the history of urban renewal up to the present,” shared Kubo. “Our hope was that after the exhibition, the book could continue the work of reigniting conversations around the complicated legacies of modern architecture, heritage, and development in Pittsburgh and other U.S. cities during the urban renewal era.” —*Destiny Vaquera*

**HINES STUDENTS TOP 4 FINALIST IN ULI HINES COMPETITION**

Multidisciplinary team’s EAVIRO District Development Plan envisions state-of-the-art baseball stadium as economic driver

April 22, 2021

**IN LATE FEBRUARY, HINES COLLEGE OF ARCHITECTURE AND DESIGN STUDENTS JIE YANG, HILLARY TELEGRAFO, JOSE MEDINA, AND PROFESSOR BRUCE RACE, FAIA, FAICP,** were excited to learn their team project submission *EAVIRO District Development Plan* earned the University of Houston a top-four finalist spot in the Urban Land Institute’s (ULI) 2021 Gerald D. Hines Student Urban Design Competition.

The ULI Hines Student Competition encourages students to create better communities, improve development patterns, and increase awareness of the need for multidisciplinary solutions in development and design challenges. Students form

interdisciplinary teams of five to devise a development program for a large-scale site in a North American city.

“All the students relied heavily on each other’s expertise and capabilities for this project,” said Bruce Race, Director of Sustainability and Resilience. “As an academic advisor for the team, I was able to support their learning experience and provide technical assistance, while Keith Richards (UH Bauer College of Business) provided real estate experience, and Tiger Lyon ‘14 (Gensler, Hines College alumnus) provided design experience.”

EAVIRO is a mixed-use, mixed-income neighborhood striving to redefine the built environment and

“All the students relied heavily on each other’s expertise and capabilities for this project,” said Bruce Race.

**BELOW:** A BIRD’S EYE VIEW RENDERING OF THE EAVIRO DISTRICT





## HISTORY, THEORY, AND CRITICISM PROGRAM GROWS WITH NEW FACULTY

*New tenure-track historian and emerging scholar fellow bring new ways to advance the College's HTC program*  
August 6, 2021

quality of life in Kansas City by cultivating economic development, producing inclusive communities, and enacting resilient design initiatives. The plan proposes a state-of-the-art baseball stadium envisioned as an economic driver having a catalytic and valuable impact on the city.

while reducing energy use by 80% and dedicating 80% of the project roofs for solar. They also pitched a new downtown shuttle loop and calculated the amount of energy required for electrifying transportation to meet Kansas City's climate action plan targets.

The University of Houston team was composed of students of multiple disciplines: Jie Yang, Hines College graduate student in Sustainable Urban Systems; Jose Medina, Bauer College MBA student; Hillary Telegrafo, Hines College undergraduate student in Architecture; Yiru Zhang, Pennsylvania State University graduate student in Landscape Architecture; and Wenjuan Li, Columbia University graduate student in Urban Design.

"Our team worked really hard on our project and are honored to be one of the top four finalists," said Jie Yang. "It was a great experience, and I think other College of Architecture and Design students should get involved in next year's competition."

The University of Houston team presented their project to a diverse jury of experts with backgrounds in commercial real estate, land use, and design on April 8, narrowly missing the top prize for their work, however, still earning a \$10,000 award.

—Destiny Vasquez

**THIS PAGE:** RENDERINGS SHOWING THE DISTRICT IN USE



The Hines College is thrilled to welcome Ramaswamy and Gutiérrez-Monroy this month and see their new perspectives and research agendas grow the HTC program at the College.

**THE UNIVERSITY OF HOUSTON GERALD D. HINES COLLEGE OF ARCHITECTURE AND DESIGN WELCOMES DEEPA RAMASWAMY THIS FALL AS ITS NEW TENURE-TRACK HISTORIAN AND TANIA GUTIÉRREZ-MONROY AS THE COLLEGE'S SECOND EMERGING SCHOLAR FELLOW.** Both Ramaswamy's and Gutiérrez-Monroy's arrival continues growing the College's history, theory, and criticism (HTC) curriculum.

The HTC program is a key component in developing students' capacities for critically understanding and intervening in the built environment. Emerging scholars and faculty have been and continue to be an essential part of furthering this mission.

"It's a huge step forward to have Tania and Deepa join in the expansion of our program. Their presence will expand the topics and issues discussed in our course offerings and bring new voices and perspectives that better represent the interests and experiences of our students," said Michael Kubo, HTC Program Coordinator at the Hines College. "Their presence is a first step in growing the HTC program into a larger department in which we can

create connections across different courses and increase the kinds of materials we offer to better develop new and relevant research."

Ramaswamy was recently awarded a \$16,000 grant from the Global Architecture History Teaching Collaborative (GAHTC) to conduct a workshop with invited architectural historians discussing the architecture history survey course and its future. The "Beyond the Survey" workshop sessions will be held virtually in January 2022. They will produce teaching materials for new introductory architecture history courses drawing on GAHTC content and Ramaswamy's ongoing work expanding the architecture history survey sequence at the Hines College.

"By revamping the survey course as the history of the design environment and also focusing on the issues and histories to be discussed in the course, I hope there will be much more of a dialogue between the history and theory courses and studio," shared Ramaswamy. "The idea of the expansion of the HTC program is to have history and theory to be an active part of the department and to find ways to incite



useful connections and conversations between the HTC and studio faculty.”

“I’m excited about the work that Deepa will be doing to transform the core of our required curriculum,” shared Kubo. “Deepa’s work will better address calls for the survey to be more global and encompass a broader series of perspectives across geographies, cultures, and times.

As the College’s new Emerging Scholar Fellow, Gutiérrez-Monroy will teach history and theory courses at the undergraduate and graduate levels while also pursuing her own research. She is currently exploring the urban forms and dynamics of Indigenous rebel communities in Chiapas, Mexico, focusing on the pathways of women who inhabit and spatially produce these cultural landscapes.

“I hope to contribute to the HTC program by drawing attention to aspects that remain unexplored in the traditional form of history and theory classes and invite students in a co-construction of knowledge to explore these topics,” said Gutiérrez-Monroy. “I am excited to work with such a diverse body of students and to learn more about the work my colleagues have developed.”

Gutiérrez-Monroy will teach Intersectionality and the Built Environment in the Fall and a second elective in the Spring. Starting this year, the Emerging Scholar Fellow will also participate in a third course or collaborative initiative at the College each year based on the content of their research, in addition to their own teaching.

“I am looking forward to having Tania’s contemporary ongoing research present in our courses, dialogue, and our program,” shared Kubo. “The Emerging Scholar Fellowship has been successful at bringing new ongoing historical research into the course content of our program. Having Tania here at the College will give us access to a new series of topics, discussions, cultures, and geographies that students will see reflected in our courses and that faculty can start building more conversations around in their own work.”

The Hines College is thrilled to welcome Ramaswamy and Gutiérrez-Monroy this month and see their new perspectives and research agendas grow the HTC program at the College.

—Destiny Vasquez



## ARCHITECTURE STUDENT ELECTED TO NAAB BOARD OF DIRECTORS

AIAS nominates Hines College student leader for influential role  
September 20, 2021

**GERALD D. HINES COLLEGE OF ARCHITECTURE AND DESIGN STUDENT NYX VALERDY WAS RECENTLY ELECTED TO THE NATIONAL ARCHITECTURAL ACCREDITING BOARD (NAAB).** She will represent the American Institute of Architecture Students (AIAS) and architecture students nationally for a two-year term through 2023.



ABOVE: NYX VALERDY

The National Architectural Accrediting Board accredits professional degrees in architecture offered by educational institutions throughout the United States. Valerdy begins her term as an officer on the board at the conclusion of the NAAB Annual Meeting on October 29, 2021.

As a student, Valerdy brings a unique perspective to the NAAB board. In her position, she is responsible for attending board meetings, reviewing visiting team reports, and voting in accreditation decisions. Once her term begins in October, she will also engage as a member of one of the board’s committees.

“I am extremely lucky and honored to have been elected among three nominated students from across the country,” said Nyx Valerdy. “It is

exciting to gain experience in my role on the board of directors and apply it to my future endeavors.”

Even before she transferred to the University of Houston in 2018, Valerdy had been an active member of the AIAS. In 2017, she first learned about the opportunity with NAAB at the AIAS national conference (FORUM). When AIAS released a call for interest in serving on committees and task forces this year, Valerdy decided to go for it.

“I really encourage students to get involved and become a part of a bigger cause,” shared Valerdy. “Whenever there is a call for action or to participate, I hope future students feel encouraged to step up, because often those actions lead to other opportunities.” —Destiny Vasquez





**OPPOSITE PAGE:** RENDERINGS OF THE HUMAN COLLABORATION LABS

## HINES COLLEGE PROJECT SELECTED FOR GREEN NEW DEAL SUPERSTUDIO

*UH students highlighted in curated project showcase forming policy*  
November 10, 2021

**THE GREEN NEW DEAL SUPERSTUDIO RECENTLY SELECTED GERALD D. HINES COLLEGE OF ARCHITECTURE AND DESIGN ALUMNI EDWIN BARAJAS, MARIANA GALVAN, AND FERDOUS KABIR'S** student project *Human/Non-Human Collaboration Labs (H.N.H.C.L)* under its Remediate section as part of its curated showcase.

The Green New Deal Superstudio is a concerted effort giving form to policy ideas by translating the core goals of decarbonization, justice, and jobs into place-specific design and projects. *Human/Non-Human Collaboration Labs* was one of 55 selected from 670 project submissions catalyzing the conversation on a wide variety of issues.

The project originated during professor Daniel Jacobs' spring 2021 ARCH 5500 *Wild Life* studio. *Human/*

*Non-Human Collaboration Labs* is a participatory research institute with the intent of developing new methodologies for remediating land through the experimentation of phytoremediation and similar ecological methods. The institute aims to form new relationships with the land, native species, and humans by experimenting with different ownership structures, introducing open-source practices, and including architectures changing with the needs of the site and serving as precedent for other sites as well.

"I think the great innovation of these students' project was not only the looseness of their structures, but the method of their distribution and articulation", said Daniel Jacobs. "Their project had a complex interchange between the structures, land, spatial remediation, and the model of ownership."

*Human/Non-Human Collaboration Labs* is located in the northwest side of Houston's Fifth Ward and is characterized by its industrial use and its adjacency to a railroad line and residences. The site serves as a meeting ground for 'Eco Art' and a medium for eco artists and scientists to continue their research, showcase their work, and engage with the public.

"The group consistently challenged themselves on the brief throughout the term. I think one of the most amazing parts of the project was the images they produced," shared Jacobs. "One of the most important things in architecture is that we are not individual producers of architectural beauty. We are complex systems of co-production. It was really exciting to see the students work together so well as a group to produce a high-level project challenging me to think in new ways, as well." —Destiny Vaquera



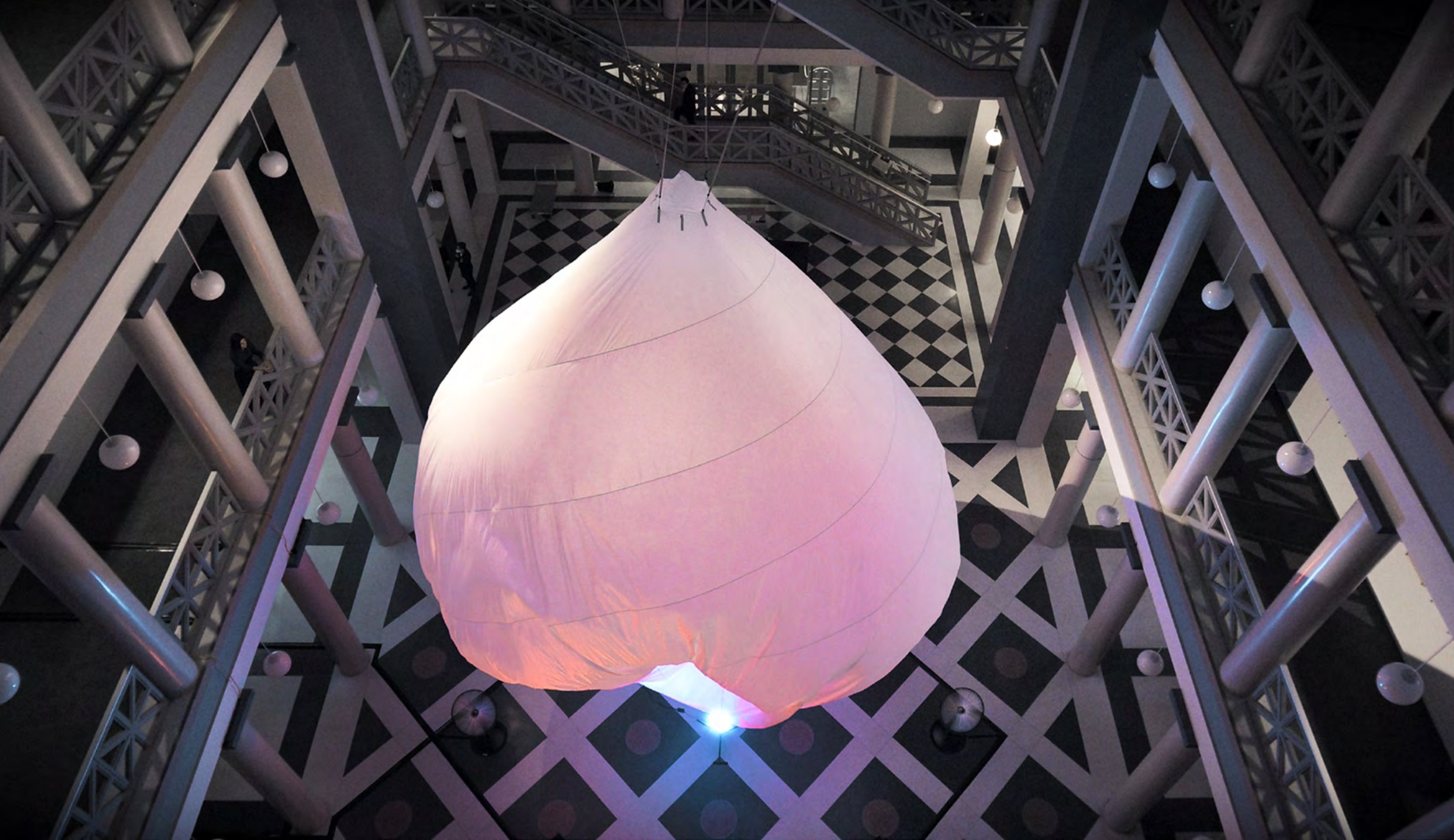



## AIRSCAPES #1 REIMAGINES ICONIC JOHNSON AND BURGEE ARCHITECTURE BUILDING

Hines College debuts 380,000 cubic feet inflated, dynamic structure  
November 16, 2021

The 380,000 cubic feet floating structure allows one's mind to move freely within this reconceived space of the "House of Education."

**THE UNIVERSITY OF HOUSTON GERALD D. HINES COLLEGE OF ARCHITECTURE AND DESIGN RECENTLY CELEBRATED ITS MILESTONE 75<sup>TH</sup> ANNIVERSARY** with a historic gala event remembering its namesake, the late Gerald D. Hines, and honoring the Hines Family. The event debuted the extraordinary installation AIRSCAPES #1, the work of Hines College professors Rafael Beneytez-Durán and Peter Jay Zweig, in the iconic Philip Johnson and John Burgee building on the UH campus.

Inspired by the project "The House of Education" (1773) of Claude Nicholas Ledoux, in 1986, Philip Johnson and John Burgee designed the University of Houston's new architecture building around an invented atrium to collect the knowledge and new ideas of architecture into a historical internal court. The atrium is embodied by the strong regularity of classic iconographies, axis, and symmetries. Stable forms are sometimes excessively signified.

AIRSCAPES #1, a dynamic pneumatic structure, challenges the values of the stable forms by using the ecology of air, the turbulence of our

times, and the rising temperature of those viewing and interacting with the airscape tempered by the ever-changing surrounding atmosphere. The 380,000 cubic feet floating structure allows one's mind to move freely within this reconceived space of the "House of Education."

AIRSCAPES #1 is air-born. It reminds us how much our language and theories of architecture have been built within a static world governed by weight and solid substances creating a dialogue of capturing and dominating space. AIRSCAPES #1 is dynamic and opens new fields of exploration where design can expand to include: negotiating space with uncertainty, where essence is no longer about heaviness but rather the qualities of being dynamic and using air as an evolving medium of architecture.

By breathing, we exchange and live in the space of air as a material substance. We accumulate aerosol substances penetrating through the lungs to the blood, to the brain, and finally to our very moods and thoughts. These accumulated forces responding to air create unpredictable internal weathers and turbulences. AIRSCAPES #1

is in a constant state of change: forgotten air, layer over layer of different temperatures, from the atrium's cold floor to the one-hundred-foot temple at the top of the "House of Education."

AIRSCAPES #1 hovers as an inspiration to a new path in

architectural education, an opportunity to look beyond static forms and enter the possibilities of dynamic forms. The 21st century is in a state of transition, consisting of moving targets, technologies, and existential climate challenges. Architecture, by its very nature, can rise to the moment.

*Sponsored by University of Houston Gerald D. Hines College of Architecture and Design. Dean Patricia Belton Oliver, FAIA, DPACSA*

*Photography by Imagen Subliminal*

**ABOVE:** AIRSCAPES #1 FLOATS ABOVE THE 75<sup>TH</sup> ANNIVERSARY GALA GUESTS





## HINES COLLEGE PROFESSOR'S BOOK HIGHLIGHTS INFLUENCE OF PERRIAND AND SEJIMA

Rodriguez focuses on transnational connections between Japan and France  
January 19, 2022



GERALD D. HINES COLLEGE OF ARCHITECTURE AND DESIGN ASSOCIATE PROFESSOR MARTA RODRÍGUEZ, PH.D., recently published her book, *Charlotte Perriand & Kazuyo Sejima: Una revolución sutil, in Spain* highlighting the relevance of Perriand and Sejima as initiators of a paradigm shift in Japanese, French, and present-day architecture.

*Charlotte Perriand & Kazuyo Sejima* addresses the transnational connections between Japan and France in the 1920s and 1980s. Perriand and Sejima were initiators of a subtle revolution, advancing highly innovative design solutions across multiple scales without sacrificing bodily awareness. Both architects began their careers designing houses as if they were chairs, with the same dimensional precision, attention to detail, material specificity, and spatial fluidity.

“The book is a manifest of what I believe,” said Marta Rodríguez. “Designing while focusing more on the human being and the environment around us is a different approach to architectural evolution that I think is extremely important.”

The complexities of Rodríguez’s book raise a new spatial paradigm

called ‘petite architecture,’ habitable furniture with the potential of urban transformation. Rodríguez conceptualizes how Perriand and Sejima transcend borders and times, ultimately inspiring and challenging architects to introduce the present time as a fourth dimension while considering the bodily experience as fuel for dynamic evolution – from the chair to the city.

“While this book is published in Spain, a large population of our architecture students is Spanish speaking. I hope students can learn more about the two women, Perriand and Sejima, and the importance of Japanese architecture”, shared Rodríguez. “My goal is to inspire more interdisciplinary approaches to architecture and connect the disciplines that we are teaching at our college.”

Rodríguez has been a visiting fellow at the Center for European Studies, Sciences Po, Paris; visiting scholar at the Center for Japanese Studies, University of California in Berkeley; and researcher by Spanish Ministry of Innovation and Development (FPU Scholarship), investigating in Tokyo. She has also written numerous papers on architectural theory and criticism and contributed to several books. —Destiny Vaquera

BELOW: THE COMIC GRAPHIC STYLE USED TO COMMUNICATE THE PROJECT'S CONCEPTS

## ARCHITECTURE STUDENTS WIN AIA FORT WORTH MERIT AWARD FOR HOMECOMING

Project highlights late congressman John Lewis and the notion of “grounding”  
April 4, 2022



THE AMERICAN INSTITUTE OF ARCHITECTS (AIA) FORT WORTH CHAPTER EXCELLENCE IN ARCHITECTURE STUDENT DESIGN AWARDS recently awarded Gerald D. Hines College of Architecture and Design students Michelle Ovanessians and Kieran Renfrow the 2022 Merit Award for their project *Homecoming*, a tribute to the life and work of the late congressman John Lewis.

The project was born from professor Emily Moore’s 4510 studio assignment to design a social justice center revitalizing a community. *Homecoming* orients itself towards serving surrounding communities of the Sweet Auburn Historic District in Atlanta, Georgia – a significant historical region containing markers and monuments from the Civil Rights Movement.

Ovanessians and Renfrow sought to create a space honoring John Lewis and perpetuating the notion of “grounding.” The idea of centering oneself within their origins and cultivating community inspired *Homecoming*. The 1950s comic graphic style used throughout the design encapsulates an “old way of representing a new idea.”

“When we first started researching, we found that the urban context lacked greenery and parks in the area,” said Kieran Renfrow. “The space allows people to regain a sense of self through plants utilized in the design, while also creating an opportunity for collaboration with the community to produce something bigger than oneself.”

*Homecoming’s* multipurpose space integrates a time-share program

allowing for utilization of the greenhouse during the day and the social garden at night, permitting communal integration. The project’s exterior and interior utilize spaces, materials, and plants as a means of “grounding,” providing a space stimulating mental health, physical health, and communal activities.

“The design itself reflects the prominent figure in history, John Lewis, while also bringing light to issues still salient in today’s society,” shared Michelle Ovanessians.

“*Homecoming* emphasizes the idea of Black people in community and creates a space fostering joy and a sense of normalcy,” said Renfrow. “Architecture has the ability to create social movements and betterment for society.” —Destiny Vaquera



## GRANT FUNDED WORKSHOP GOES BEYOND THE SURVEY

Workshop critically examines introductory architectural history survey courses  
May 26, 2022

BELOW: SCREEN CAPTURES OF THE WORKSHOP SESSIONS IN PROGRESS

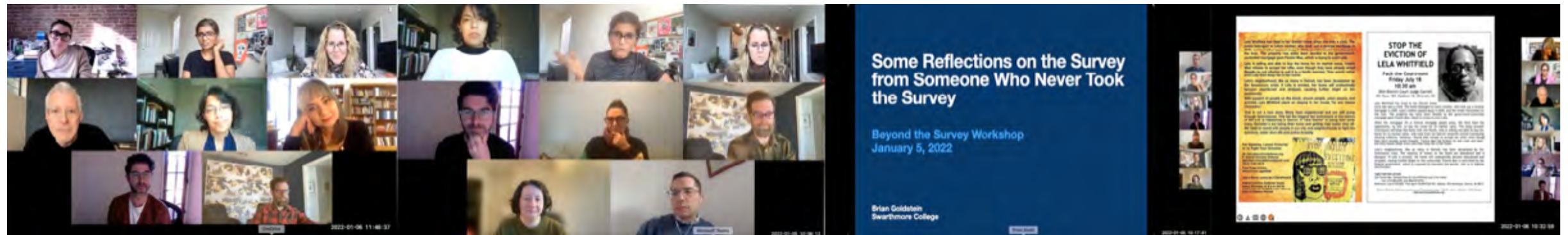

EARLIER THIS YEAR, UNIVERSITY OF HOUSTON GERALD D. HINES COLLEGE OF ARCHITECTURE AND DESIGN ASSISTANT PROFESSOR DEEPA RAMASWAMY organized and led a workshop to critically evaluate the teaching of architectural history survey courses. The *Beyond the Survey* workshop resulted as part of a grant Ramaswamy received from the Global Architectural History Teaching Collective (GAHTC) and The Andrew W. Mellon Foundation.

Over one week, ten architectural historians asked: If the rigid two-semester space of the survey were reimagined, what could it become? What changes could be made to the form and structure of the survey course to kindle cultural and historical literacy, critical thinking, and interdisciplinary research methods? How can we better root architectural and urban histories in

ecological, political, social, material, and cultural histories?

Ramaswamy began teaching at the Hines College in the fall of 2021. She was inspired to pursue the grant while designing her survey syllabus for over 220 students from diverse backgrounds, disciplines, and even colleges within the University. She realized that working in isolation may not be the best way forward.

After several discussions with the College's History, Theory, and Criticism (HTC) coordinator Michael Kubo, Ramaswamy submitted a grant proposal to the Global Architectural History Teaching Collective and the Andrew W. Mellon Foundation. She received the grant in 2021.

Ramaswamy designed the workshop to bring together historians, architects, and educators currently

teaching the architectural survey course and possibly having many of the same questions she had.

"Historians and architects have spent some time talking about the content of the survey course," said Ramaswamy. "However, we have not spoken much about the rigid form and structure prevalent in most universities across the United States. The survey course has historically aspired to cover so much material in just two semesters. We may need to pause and question the futures and potentialities of this model."

The workshop was framed by several invited talks from architectural historians who had successfully changed their courses over time. The discussions covered methodological dilemmas, including questions of chronology and historical progression and the practical issues of NAAB

criteria, rubrics, assignments, and exams. At the end of the workshop, along with the videos of the lectures and discussions, the workshop participants also produced a shared set of deliverables, including reading lists, assignments, course outcomes, and syllabi.

The workshop provided a platform for insights into other contexts, disciplines, and universities.

"As a group, we scrutinized the complexities inherent in teaching the architectural survey course," shared Ramaswamy. "By the end of the workshop, we all had adapted some of these ideas into our courses."

The insights gained will undoubtedly advance the HTC program at the Hines College. Ramaswamy is incredibly grateful to the GAHTC and the community of architects,

historians, and educators who supported the workshop.

*Beyond the Survey* included a total of ten architectural historians. The four invited speakers included Brian Goldstein (Swarthmore College), Andrew Herscher (University of Michigan), Mrinalini Rajagopalan (University of Pittsburgh), and Sara Stevens (University of British Columbia). Other participants included Bryan Norwood (University of Texas at Austin), María González Pendás (Cornell University), Aaron Cayer (University of New Mexico), Nikki Moore (Wake Forest University), Tania Gutiérrez-Monroy (University of Houston), and Deepa Ramaswamy (University of Houston).

—Symone Daniels



# ENKEL



(Swedish): "Enkel"  
simple, elegant

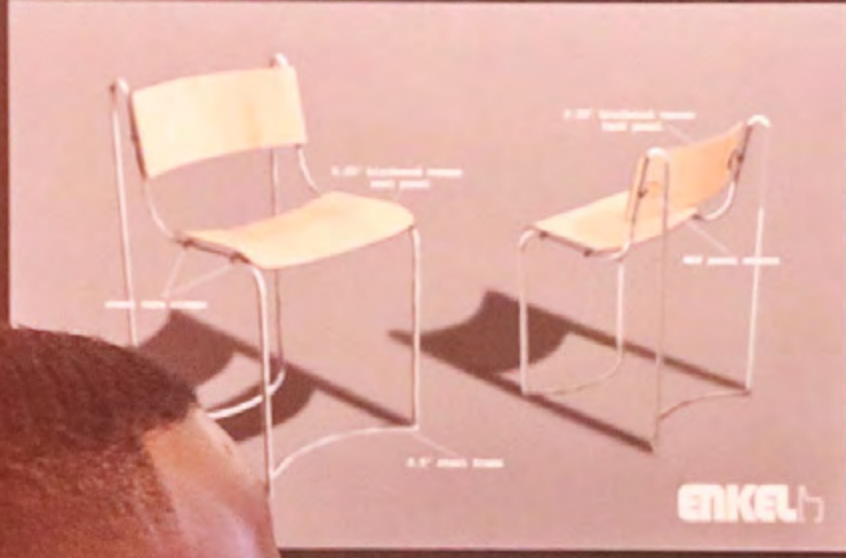

## ica

Mechanica is a modular seat  
system. The system's  
plates represent nature and the  
machines. Mechanica can be disassembled.

The simple  
creation  
the un-  
ground,  
their b







# INDUSTRIAL DESIGN

## DIRECTOR OF INDUSTRIAL DESIGN

The College's founding director of the Industrial Design (ID) EunSook Kwon left the program in fall 2020 to pursue another opportunity after 14 years leading the award-winning program. Co-directors Jeff Feng and Mark Kimbrough currently lead the ID program during the on-going search for a new director. In the absence of a director, the program continues receiving accolades nationally and internationally.

## RETURN TO SOUTH BY SOUTHWEST (SXSW)

In 2022, the annual SXSW conference returned in-person for the first time since the pandemic. Our Industrial Design program was on its way to exhibit at SXSW in 2020 when the conference was abruptly canceled due to COVID-19. This year's return to the conference allowed the College to promote its program and student work among industry professionals, establishing connections to further advance ID at the Hines College.

**OPPOSITE PAGE:** THE 2022 INDUSTRIAL SENIORS POSE FOR A PHOTO AFTER THEIR SPRING SHOW

**BELOW:** INDUSTRIAL DESIGN STUDENTS REPRESENT THE COLLEGE AT SXSW





# INDUSTRIAL DESIGN STORIES

## HINES COLLEGE INDUSTRIAL DESIGN STUDENT ONLY AMERICAN TO WIN ANNUAL GLOBAL PRIZE

Gray receives bronze award for innovative scooter design  
January 11, 2021

**EARLY DECEMBER, SENIOR INDUSTRIAL DESIGN STUDENT ANNALISE GRAY WAS SURPRISED** with the news her studio project, the *Hippo Storage Electric Scooter*, was named a finalist in the 2020 15th Annual China Hardware Products International Industrial Design Competition Awards. The announcement came during the presentation of her design to fellow studio classmates. Gray's *Hippo* went on to receive the Bronze Prize in the scooter and motorcycle category, recognized as this year's only winning submission by an American designer.

The project originated as a studio assignment by Professor Mark Kimbrough charging students to create a motor vehicle that was not a car and encouraged each student to submit their design into an annual competition. Due to the ongoing COVID-19 pandemic, Gray chose to enter her project to the competition held by the Zhejiang University of Technology School of Architecture and Design because the competition only required a digital submission. Fabrication resources and opportunities have

been limited to students since the start of the pandemic.

"Automotive design transportation is not my strong suit, so at first I was not excited about the project," said Gray.

Initially, Gray considered creating a scooter that was useful for people who live in the city, including college students, alleviating the burden of transporting laundry several floors or down the street to the laundromat. When she discovered Kimbrough required the design to be electric, Gray pivoted and developed a multipurpose scooter lending itself to city transportation.

"I was thinking of people who live in city apartments or studios and how they commute to work without owning a car," Gray explained. "I have ridden traditional electric scooters, but they are hard to transport a lot of items while also finding your balance."

Gray designed *Hippo* to provide city users with a safe way to efficiently move throughout the city quickly while also securely storing items on the go. The spacious compartment



**ABOVE:** GRAY'S HIPPO SCOOTER, A FOLDABLE DESIGN

utilizes smartphone technology to lock and unlock the *Hippo* case, making it easier for users to manage. Users can also take advantage of the retractable phone mount, wireless charging, and two cupholders.

"I wanted to avoid scooters that fold up because they are just awkward," said Gray. "I felt that if this is something you are going to ride to your workplace and then keep in your office, it should not look ridiculous or even like a scooter when it is stored."

Three additional UH projects also made it to the finals in the annual competition: *Argo – Trace* by Joshua Alarcon, Anthony Lozano, and Francisco Grandi; *Mericycle* by Alexa Baeza; and *Neo* by Diana Hernandez.

"This international design competition was a unique opportunity for our students to compete on the world stage," said Kimbrough. "Annaleise was able to define research parameters of urban transport and life that ultimately

created a nexus of urban living around the world."

The Hines College's Industrial Design program was established in 2003, the first of its kind in a four-state region. Alumni and students have consistently received awards and recognition, including top prizes from the Industrial Designer's Society of America, International Housewares Association, International Contemporary Furniture Fair, Dubai Global Grad Show, and Makeup NYC. —Stephen Schad





**AT LEFT:** THE MANTA CHAIR, DESIGNED OUT OF STEEL AND GIVEN FORM THROUGH MACRAME WEAVING

## INDUSTRIAL DESIGN STUDENT EARNS FIRST PLACE AWARD IN BIENENSTOCK COMPETITION

*Student designs award-winning hammock-like chair named Manta*  
March 26, 2021

**GERALD D. HINES COLLEGE OF ARCHITECTURE AND DESIGN INDUSTRIAL DESIGN STUDENT ANNA BIBIKOVA** recently received first place in the prestigious 2021 Bienenstock Furniture Library Competition for her chair, *Manta*, a hammock-like net woven around a fluid metal frame.

The project was conceived and fabricated as a result of professor Jeff Feng and Aaron McEuen's studio assignment encouraging students to enact their personal interests while designing a chair. Bibikova sought to develop a chair creating an escape from individuals' busy lives while sitting in a "shapeless" structure.

"This assignment was a highly effective way for students to express themselves and produce highly original designs," said Jeff Feng. "Anna's design was one of the best, and it was also submitted in the International Contemporary Furniture Fair (ICFF) in New York in 2020."

The Hines College's industrial design program is not new to the Bienenstock Competition. This year is the third time the College has placed in the competition, winning first place in 2018 and second place in 2019. Bibikova's chair design received a \$5,000 prize, and the College's industrial design program also received a \$1,000 award.

Comfort, relaxation, and the carefree feeling experienced near the ocean inspired Bibikova's design. The design combines modern, sculptural form with traditional macrame weaving techniques constructing a hammock-like lounge chair for use in a home or public setting.

"I am highly honored to have my design recognized in this competition and to be able to share this design with others," shared Anna Bibikova. "This has encouraged me to apply to other competitions and continue designing." —*Destiny Vaquera*

## ID STUDENT AWARDED SUMMER UNDERGRADUATE RESEARCH FELLOWSHIP

*Hines College student brings attention to plastics recycling on campus*  
July 15, 2021



**ABOVE:** BAKER WITH A PIECE OF MATERIAL MADE FROM RECYCLED PLASTICS

**THE UNIVERSITY OF HOUSTON RECENTLY AWARDED GERALD D. HINES COLLEGE OF ARCHITECTURE AND DESIGN INDUSTRIAL DESIGN STUDENT ANNE-ELISABETH BAKER** with a Summer Undergraduate Research Fellowship (SURF), under the direction of faculty advisor Andrew Kudless, to further her research on recycling plastic and generate innovative ways of fostering sustainability on the University's main campus.

Along with Hines College alumnus Steve Love, Baker is a co-founder

and member of Precious Plastic UH, whose mission is to reduce plastic waste by rethinking the everyday use of plastics. Through a donation from Keep Houston Beautiful, Precious Plastic UH purchased a plastics shredder for the Burdette Keeland, Jr. Design Exploration Laboratory. In the workspace, Precious Plastic UH aims to have three other machines including an injection machine, a large sheet press, and a compression oven to help tackle the plastic waste problem. This workspace will assist in transforming plastic waste into valuable raw materials or products,





**ABOVE:** PLASTIC IS CLEANED AND SHREDDED BEFORE BEING FORMED INTO A SHEET OR BLOCK

including furniture, functioning tools, and modular elements.

“I was eager to co-found the Precious Plastic chapter here at the University of Houston with Steve and begin taking part in events and ideas focused around sustainability,” said Anne-Elisabeth Baker. “This upcoming year, I am hoping we can collaborate with other students on campus to distribute materials, create more drop-off stations to collect plastics, and inform others on what we are doing here at Precious Plastic UH. This research will hopefully begin to pique others’ interests in the idea of recycling and plastic consciousness.”

Originally from a small town, Baker aims to use this research in creating new recycling infrastructure systems in small towns where there is currently little opportunity for communities to recycle. Her research develops processes for cleaning, sorting, and shredding the plastic along with safety material for others to use in the workspace. Through her research, a

variety of informative plastic blocks will be produced to serve as reference materials for students. The hope is these materials will open minds to ways recycled plastics can be repurposed and identify opportunities for growth in the processes.

“I became involved in the Industrial Design program at the College because I wanted to focus on sustainability, specifically in packaging and how we can reduce the amount of waste produced by everyday consumers,” shared Baker. “The Industrial Design program has taught me to be resourceful and think more critically about the world around me.”

Later this summer, Baker and other members of Precious Plastics UH will demonstrate the utilization of the plastic shredder and the systems in place for her research.

“The Houston region is one of the largest producers of plastics, and we have the responsibility to work towards a circular economy maximizing the reduction, reuse, and recycling of plastics,” shared Kudless. “Designers have a critical role to play in this process and Anne-Elisabeth’s research will help the Hines College develop new sustainable fabrication methods. Her project is the first of many projects that the College’s new Advanced Media Technology Lab will support imagining the future of fabrication and design.” —*Destiny Vaquera*

## COLLEGE NETWORK JUMPSTARTS ALUMNUS’ CAREER IN CALIFORNIA

*Hines Leadership Council connects alumnus Josh Probst to top product design firm and engineering development company*  
August 20, 2021

**WHEN GERALD D. HINES COLLEGE OF ARCHITECTURE AND DESIGN ALUMNUS JOSH PROBST GRADUATED IN 2019**, he probably never imagined the world awaiting him. With many successes following his graduation, Probst was still waiting to land his dream job. That’s where Hines College Leadership Council member Robert Del’Ve entered the picture.

During a quarterly Leadership Council meeting, Del’Ve, a design industry veteran, was quite impressed by Probst’s work. Following the meeting, Patricia Belton Oliver, FAIA, connected Del’Ve with Probst, and the rest was history. The Leadership Council member connected the alumnus with a prominent industry contact, launching his industrial designer career at RKS in Thousand Oaks, California.

The Leadership Council is an integral part of the College’s industry connections and external reach. Its membership comprises professionals in architecture, interior architecture, industrial

design, construction, real estate, and other industries integral to Houston’s design community. As advocates of the Hines College, Council members help bridge the gap between industry and academia, helping move the College forward and prepare students for successful careers.

“It’s so hard for all students to find that ‘perfect fit’ after they graduate,” said Robert Del’Ve, Managing Director of Project Management at CBRE. “Josh and I had similar passions for industrial design, and I had several contacts within the industry I could put him in touch with. Ravi Sawhney, the founder and CEO of RKS, is a dear friend of mine, so I sent him Josh’s CV and set up a call between the two of them.”

After completing an internship with the firm, Probst officially became a full-time industrial designer at RKS in March 2021. RKS is a design and innovation firm consulting with clients and engaging in various day-to-day work, including research, computer-aided design, and prototyping.

“I would highly encourage future students to get internships to prepare them for the real world and help them make connections within the industry.”





**AT LEFT:** PROBST RIDES HIS SENIOR THESIS PROJECT, AN ELECTRIC MOTORCYCLE CALLED MAYA

“I would highly encourage future students to get internships to prepare them for the real world and help them make connections within the industry,” shared Probst. “Understanding where you want to go and what connections can help you get there is essential.”

In Probst’s spare time, he is designing a new concept utilizing a 2018 Husqvarna Vitpilen 401 with the idea that gas motorcycles will one day become obsolete. In 2020, Probst was recognized as the “Emerging Product Designer of the Year” at the DNA Paris Design Awards for his motorcycle design, MAYA.

“I had no idea that designing the motorcycle for my thesis back in 2019 would lead me to California”, shared Probst. “I am extremely grateful for Robert Del’Ve and Professor EunSook Kwon.”

“From the next generation of designers, I hope to see the passion and a desire to better processes, experiences, or designs that make something better for the environment, easier to use, and simpler to understand,” shared Del’ve. “Josh gained the desire, passion, and knowledge he needed through the Hines College’s ID program, and it has been a pleasure working with him through his journey.” —Destiny Vaquera



## INDUSTRIAL DESIGN PROFESSOR NAMED 2021 IDSA YOUNG EDUCATOR

Professor George Chow awarded for his impact on Industrial Design education  
October 14, 2021

THE INDUSTRIAL DESIGN SOCIETY OF AMERICA (IDSA) RECENTLY AWARDED GERALD D. HINES COLLEGE OF ARCHITECTURE AND DESIGN ASSISTANT PROFESSOR OF INDUSTRIAL DESIGN GEORGE CHOW WITH THE 2021 IDSA YOUNG EDUCATOR AWARD.

Established in 2008, the annual national award acknowledges junior faculty, non-tenured, or tenure-track IDSA member educators who have significantly impacted industrial design education within the early years of their academic careers.

Since Chow joined the University of Houston faculty in 2016, he has taught many courses and studios of all levels, including a course on designing for a sustainable future and a graduate master thesis course, among others. His primary focus areas are sustainability and social impact design while creating a meaningful and impactful educational experience for his students.

“Receiving this award has been a dream come true for me as I have



dreamt of winning this award since I started teaching at UH. I am truly honored and humbled to have received it,” said Chow. “I am very thankful for all of my students – past, present, and future – for allowing me the honor and opportunity to invest in their lives.”

Chow serves as the IDSA Southern District Chapter Representative. His primary responsibility is serving as a liaison, resource, and bridge between city chapters in the Southern District – Atlanta, Austin, Charlotte, Dallas-Fort Worth, and Miami. For the first time in its history, IDSA officially launched a Houston chapter on October 7th with hopes of expanding the design community in Houston,

especially between industrial design professionals and UH industrial design students.

“IDSA is the primary professional organization in our field,” shared Chow. “It has provided a community for designers to encourage and support one another and celebrate the achievements of its members. Without IDSA, we wouldn’t have a network of people brought together by a common love of design. We wouldn’t have the conferences, deep dives, selection and chapter events, education symposiums, resources, and a collective platform to advocate for positive design change. I am incredibly thankful for the design family.” —Destiny Vaquera

“This recognition not only brings more public awareness to the Gerald D. Hines College and myself, but also the practice of industrial design.”

## HINES PROFESSOR ELECTED TO THE NATIONAL ACADEMY OF INVENTORS SENIOR MEMBERS

Feng recognized for success in commercialization and production of impactful technologies  
February 28, 2022

### THE NATIONAL ACADEMY OF INVENTORS (NAI) SENIOR MEMBER ADVISORY COMMITTEE AND BOARD OF DIRECTORS

recently elected Gerald D. Hines College of Architecture and Design industrial design associate professor Jeff Feng to the Class of 2022 NAI Senior Members for his success in licensing, patents, and commercialization, as well as producing technologies impacting the welfare of society.

NAI Senior Members are faculty, scientists, and administrators from NAI Member Institutions who have demonstrated remarkable innovations while educating and mentoring the next generation of inventors. The 2022 class of Senior Members consists of 83 of the world’s best emerging academic inventors.

“I am honored to be elected by the National Academy of Inventors as an NAI Senior Member,” said Jeff Feng.

“This recognition not only brings more public awareness to the Gerald D. Hines College and myself, but also the practice of industrial design. It will potentially strengthen and support the expansion of collaboration with other disciplines and industries.”

The Hines College’s industrial design program emphasizes the interaction of individuals with objects and their environment by addressing the cultural, ergonomic, technological, ecological, and social factors leading to more useful and meaningful products and services. Feng teaches studios at the junior, senior, and graduate level at the Hines College.

“I have been a designer for almost thirty years. In my personal experience, people’s understanding about the practice of industrial design is still limited,” shared Feng. “Design is a unique practice and investigation through the integration of problem-solving functional innovation, interactive experience, and appearance. With this NAI exposure to industrial design, I hope other colleges and individuals in our University will learn more about the potential of design practice, thus collaborating with our program.”

Feng will officially be inducted as an elected Class of 2022 NAI Senior Member at the Senior Member Ceremony hosted during the NAI 11th Annual Meeting June 14-15 in Phoenix, Arizona. —Destiny Vaquera



# Green Thumb

Green Thumb began to address farm-to-table issues. One of the main goals of the census population to healthy food options. This is a great way to get all kinds of them with access to local food. The best source of produce is local and it's a resource in a way that allows the city to become more self-sufficient. The idea is to bring in the city and the other is the idea of local production in the urban environment.



Step 2: Collaborate



Public Consulting Office  
2013.10.10





# INTERIOR ARCHITECTURE

## INTERIM DIRECTOR OF INTERIOR ARCHITECTURE

Sheryl Tucker de Vazquez serves as the current interim director of Interior Architecture. Sheryl brings a fresh approach to the program which will allow the program to soar to new heights under her leadership.



## NEW INTERIOR ARCHITECTURE FACULTY

The College welcomes two new assistant professors of Interior Architecture in fall 2022. Both professors are no strangers to the College. Dijana Handanovic graduated from the Master of Architecture program in 2015 and has taught at the College as an adjunct faculty member. Ophélie Mantz is the director of the Materials Research Collaborative (MRC) and has taught at the College as an adjunct faculty member.



**TOP TO BOTTOM:** SHERYL TUCKER DE VAZQUEZ, DIJANA HANDANOVIC, AND OPHÉLIE MANTZ

# INTERIOR ARCHITECTURE STORIES

**AT RIGHT:** BRUTON'S GAME OF TABLES & CHAIRS

## INTERIOR ARCHITECTURE PROFESSOR HONORED WITH INTERNATIONAL DESIGN AWARDS

*Bruton's social engagement project highlights egalitarian social interaction*  
February 5, 2021



**THE 14TH ANNUAL INTERNATIONAL DESIGN AWARDS (IDA) HAS HONORED GERALD D. HINES COLLEGE OF ARCHITECTURE AND DESIGN** Professor and Director of Interior Architecture Alan Bruton with two product design awards for his social engagement project *Salon, a game of Tables & Chairs* – bronze prize for the category *Society/Designs for Social Impact*, and gold prize for the category *Toy Design/Board and Card Game*.

*Salon* reimagines the gridded Chessboard to produce an environment allowing for an egalitarian social interaction amongst players. The board game is one aspect of a four-scale spatial project which utilizes the technique of recursion — a setting appearing within itself larger, smaller, and in

this case even virtually, scaleless, using the tools of augmented and virtual reality.

“The project started with me 3D printing furniture to place on a chessboard as an art piece critical of the antagonistic, hierarchical, and war-like nature of chess,” said Bruton. “I wanted a more egalitarian representation of society in my house than Chess.”

Bruton was inspired by the psychological, sociological, and sometimes political dimensions in how individuals constantly rearrange chairs and tables in rooms where they gather. Through many iterations of *Salon*, Bruton has been able to play the game with students, friends, strangers, and colleagues at academic conferences where the game has

been presented in the context of his research into ludic spaces in general, as recently published as a chapter in the book *Interior Provocations, History Theory and Practice of Autonomous Interiors*, Routledge Press 2020.

“The point of the game is to bring people together at the table,” shared Bruton. “This game concerns itself with the quality and impact of our living together in space.”

Bruton has focused on interior space issues for decades, working with clients and collaborators on their organizational and expressive spatial needs in New York, Detroit and now Houston, developing his interest in bringing to light the forces of the psychological, social, and physical dimensions at play in the interior.

—Destiny Vaquera



## ARCHITECTURE STUDENTS HONORED WITH AIA HOUSTON CONCEPTUAL DESIGN AWARD

UH students awarded for their social justice project re-envisioning Montgomery Peace and Justice Memorial  
September 27, 2021

The American Institute of Architects (AIA) Houston recently awarded Gerald D. Hines College of Architecture and Design students Nastassia Chua, Rebekah Mireles, and Sharon Lott with a 2021 Conceptual Design Award for their project, *Strange Fruit: An Intervention at the Peace and Justice Memorial* in Montgomery, Alabama.

Professor Sheryl Tucker de Vazquez encouraged her students to design a space integrating offsite parts of the Memorial, while also creating a dialogue within the confines of the existing Memorial itself. Chua, Mireles, and Lott sought to maintain the *empty quality* of the Memorial courtyard space by lifting the building in their design.

“Not only was the project conceptually strong, but it was also well-developed in terms of all aspects of the architectural program and incorporating sustainability,” said Vazquez. “I am particularly proud of how the entire studio took on the issue of social justice in the wake of George Floyd and showed that you can deal with social justice issues and still create very highly conceptual architecture.

Their proposal lived up to the Memorial and the original sublime piece of architecture in which we were intervening.”

The design evolved from the idea of the flowing human movement along the margins. A processional path between the intervention and concrete walls of the memorial extends the ramped procession of the existing memorial. This spatializes African American existence along the margins of American society in the wake of slavery. In one continuous motion, people, light, and air spiral downwards between the existing Memorial and the intervention before terminating at the lowest point of the reflection space.

The path defines the program’s spaces. It becomes the center lobby as you first pass beneath the raised ground, as well as the exhibition space along the perimeter, before finally pooling into the reflection space and auditorium. The idea for the center structure and roof was developed from this parti, where the path creates a negative of its imprint borne up by thin columns parallel to the hanging coffins of the surrounding memorial. A processional

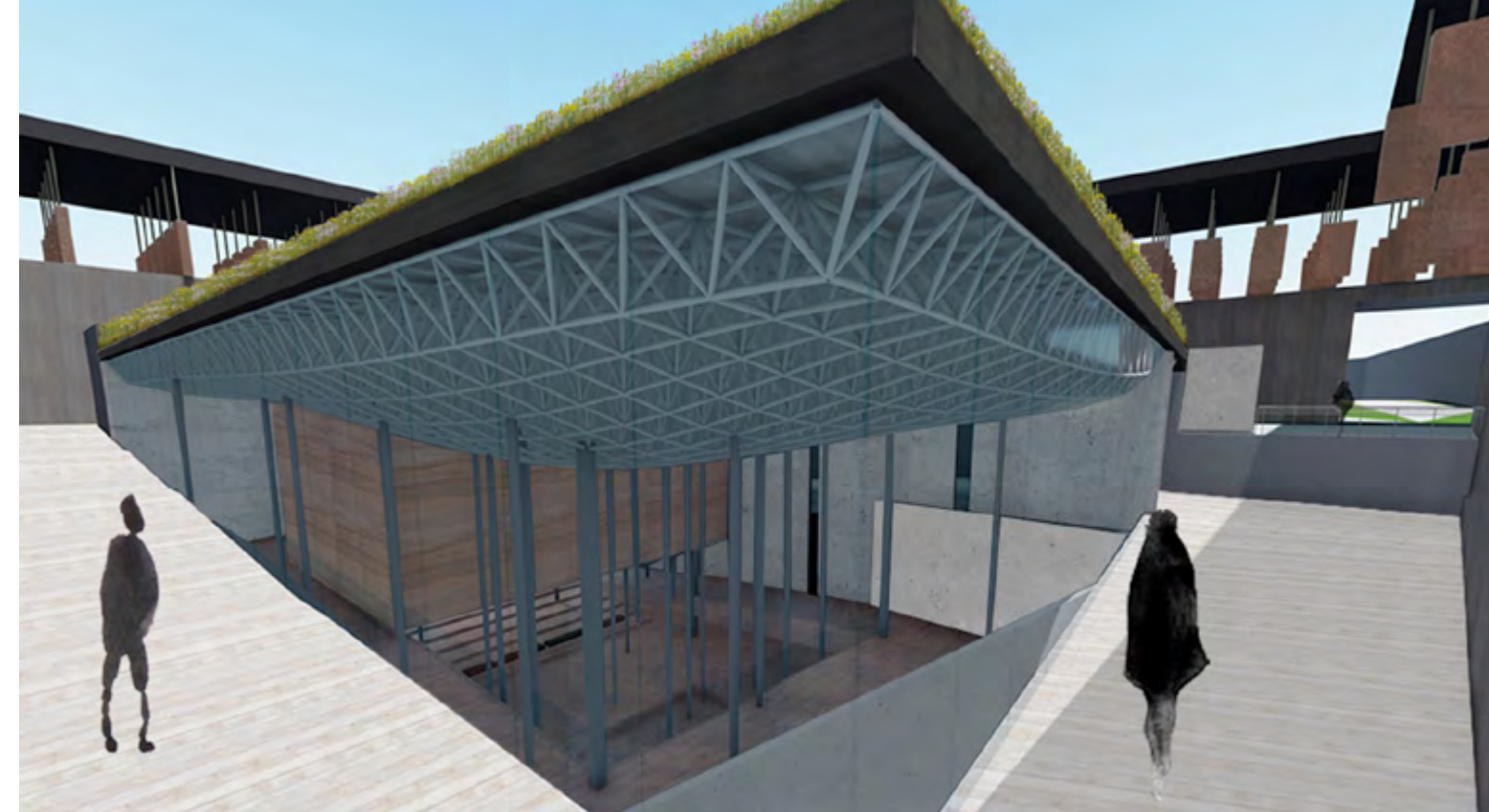

path to the center, between the intervention and concrete walls of the courtyard, extends the ramped procession of the existing memorial carved out of the earth. The center contains spaces for assembly, classrooms, exhibitions.

The semi-submerged architecture reflects how African Americans were forced to carve spaces out of the American landscape for self-liberation. The uplifted, green roof embodies the burden of racism that the entire American people should help carry, while also offering a hopeful space.

Chua, Mireles, and Lott selected the poem *Strange Fruit*, covered by artists such as Nina Simone and Eartha Kitt, to inspire the concepts behind their design. They also chose the abstract artist Torkwase Dyson

to look at the memorial from a deeper perspective. Dyson’s work is liberating and interdisciplinary, connecting architecture, infrastructure, environmental justice, and social justice.

“We wanted to deepen the meaning of the memorial and provide a space to talk about the tragedies that the memorial shines light upon,” shared Rebekah Mireles. “Torkwase Dyson’s work informed many of our feelings toward the project in order to drive our design to be impactful and highlight the meaning behind the building.”

“Winning this award was very important as it brings recognition to the project and the meaning behind the Memorial,” shared Nastassia Chua. “I think it is important for

future students working on projects connecting social justice issues and architecture to research and understand the meaning behind a site while being mindful of different cultures and history.”

In 2020, the AIA Houston recognized Tucker de Vazquez’s studio with another Conceptual Design Award for their Third Ward libromat. Earlier this year, Tucker de Vazquez also received a Graham Foundation grant for research surrounding how Black hair inspires architecture embodying Black identity.

Hines College alumni and faculty from Content Architecture, Michael Hsu Office of Architecture, UltraBarrio, and more were also honored with Design Awards this year. —Destiny Vaquera

OPPOSITE PAGE: AN EXTERIOR RENDERING OF THE STUDENTS’ CONCEPTUAL DESIGN FOR *STRANGE FRUIT*



# DESIGN/BUILD

## LOOKING FORWARD

Among 300 alumni have participated in the College's Design/Build collaboration during the program's over 30 year history at the Hines College. In 2021, Provost Short awarded the College a "Key Initiatives" award, opening a search for the new inaugural faculty director of the Keeland Design Exploration Lab, a new research liaison officer staff position, and two graduate assistant student positions to advance the Design/Build program.

As the College continues to look forward to the future, it is exploring the possibility of establishing a 501(c)(3) organization focused on design/build. The new venture will greatly expand the College's ability to explore more substantial design/build opportunities for our students and independently build speculative projects

# DESIGN/BUILD STORIES

## HINES COLLEGE AND VALENTI SCHOOL OF COMMUNICATION JOIN FORCES TO DEVELOP CUTTING-EDGE TECHNOLOGY

*Collaboration brings about AutoBox Mobile Digital Display*  
January 11, 2021

**GERALD D. HINES COLLEGE OF ARCHITECTURE AND DESIGN PROFESSORS PATRICK PETERS AND JASON LOGAN, ALONG WITH NINE GRADUATE ARCHITECTURE STUDENTS**, joined forces with the University of Houston Jack J. Valenti School of Communication to design the *AutoBox Mobile Digital Display*, a portable venue for the digital screening of student's work that can be deployed both inside and outside.

Professors Peters and Logan and the students – Vanessa Beckett, Montserrat Bribiesca, Hannah Hemmer, Brian Liu, Joshua Rodriguez, Nora Segura, Naraphat (Pear) Siriko, Tiffany Thai, and Courtney Warren-Williams – designed *AutoBox*, utilizing construction and electronic components, software, and materials from across the globe. It includes software from Israel, horizontal glides from France, wheels and

aluminum composite panels from the United Kingdom, screens from China, vertical actuators from California, and custom-fabricated stainless-steel hinges from Houston.

"After we started working on the project, it became very clear this was the ideal solution for COVID-19 protocols", said Professor Patrick Peters. "After what we all experienced during the pandemic, *AutoBox's* portable design allows us the ability to gather and have a common event that is socially distanced and outdoors."

*AutoBox Mobile Digital Display* was the 2020 project of Hines College's Graduate Design/Build Studio, a 32-year community engagement initiative. The studio offers the master of architecture students an opportunity to see their ideas evolve from conception to completed construction while demonstrating full-scale the implications of the students' aspirations, measuring the quality of their design thinking against the rigorous stand of the built reality.

Hines College master of architecture alumnus and president of Aria Signs and Display, Shaya Attaei, provided the fabrication services pro-bono and donations of paint, steel, and aluminum materials. Dr. Steven Wilkerson, PE, president of Zia Engineering, provided the structural engineering services pro-bono and collaborated with the students on the design.



"Designing *AutoBox* encouraged me to apply my skillset accordingly, as well be a team player throughout the process," said Brian Liu.

"It allowed us to use both our imagination and critical thinking skills to come up with a design that was truly unique. It also allowed us to look at architecture from a different perspective, which helped me personally as a designer," shared Courtney Warren-Williams.

"The virtual team design process proved to be the most challenging; however, it was rewarding to see the completed model in person," said Nora Segura. "I believe *AutoBox* will impact future students' education by showing that while architecture does heavily concentrate on the built environment, there is a certain level of architecture and design that goes into everyday and not-so-everyday products," shared Warren-Williams.

The Hines College of Architecture and Design recently utilized *AutoBox*

at the 75th Anniversary Gala and IDesign week late last year. On December 15, 2021, Dr. Jennifer Vardeman, director of the Jack J. Valenti School of Communication, featured *AutoBox* as the venue to screen fifteen student films in the school's broadcast studio at its inaugural *Experience Valenti Showcase* event.

"With *AutoBox* being cutting-edge technology, we believe that it helps students visualize how their films and products can be used in the new media era. It also encourages them to be able to think more creatively and be more entrepreneurial in terms of how they visualize and bring their stories to a greater life than ever before", said Dr. Jennifer Vardeman, Jack J. Valenti School of Communication associate professor and director. "The architecture students largely developing this project during the pandemic is a perfect example of the power of the students here at the University, their limitless creativity, resilience, and ability to innovate." —*Destiny Vaquera*

**OPPOSITE PAGE:** A RENDERING OF HOW THE *AUTOBOX MOBILE DIGITAL DISPLAY* COULD BE USED FOR COMMENCEMENT



# CENTER FOR SUSTAINABILITY AND RESILIENCE (CeSAR)

## \$1 MILLION NATIONAL SCIENCE FOUNDATION GRANT

The College's Center for Sustainability and Resilience continues expanding its reach, receiving its first \$1 million grant from the National Science Foundation in 2021. Professor Bruce Race collaborated with faculty from the University of Houston, Vanderbilt University, and University of Texas Health Science Center.

## TEXAS AMERICAN PLANNING ASSOCIATION AWARDS

CeSAR received a 2021 Texas American Planning Association (APA) Resilience Gold Award for its *Habitat for Humanity Robins Landing* project and is set to be awarded another 2022 Texas APA Resilience Gold Award for its *Ruffino Hills Landfill* project.

### Regional View PM2.5 & Outliers

**Top PM2.5 Sensor Readings**

- PM2.5 Sensors
- 8 Counts
- 9 Counts
- 14 Counts
- 15 Counts
- 18 Counts

**NEI PM2.5 Point Sources**

- ≤13.37
- ≤32.96
- ≤74.77
- ≤154.10
- ≤285.54
- ≤941.89

**EISCREEN PM2.5 Readings**

- ≤12.5
- ≤25.0
- ≤37.5
- ≤50.0
- ≤62.5
- ≤75.0
- ≤87.5
- ≤100.0

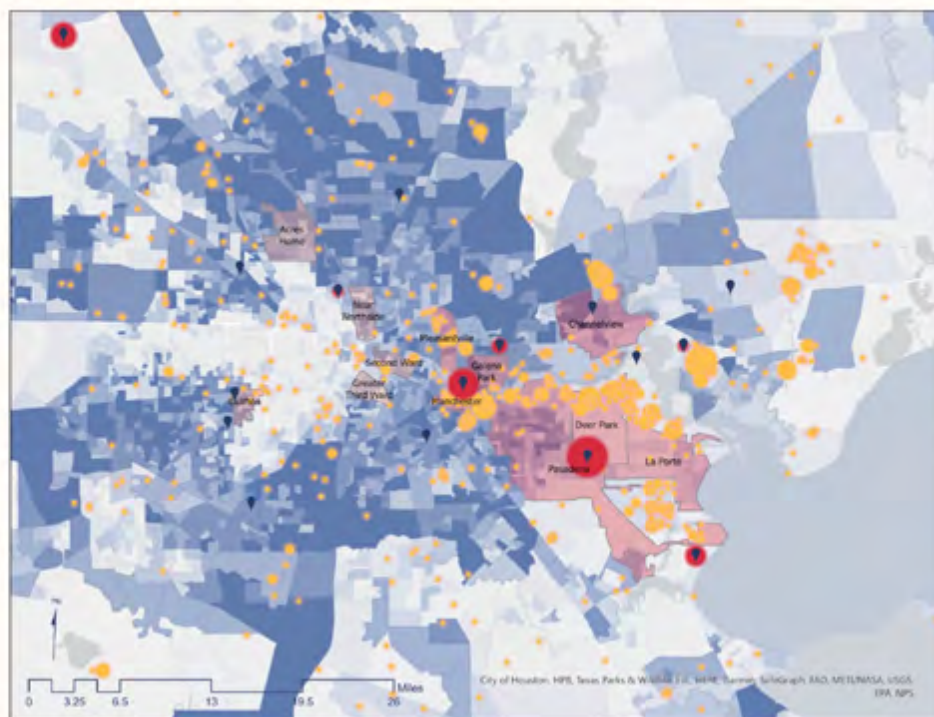

**ABOVE:** DATA VISUALIZATION FROM CeSAR'S HABITAT FOR HUMANITY ROBINS LANDING PROJECT

**OPPOSITE PAGE:** HINES COLLEGE PROFESSOR BRUCE RACE WILL HELP DEVELOP A PLAN TO HELP REDUCE ECONOMIC BARRIERS TO ELECTRIC VEHICLE OWNERSHIP

# CeSAR STORIES

## DEVELOPING STRATEGIES TO INCREASE ACCESS TO ELECTRIC VEHICLES

*New Project Funded by National Science Foundation Targets EV Ownership in Low-Income Communities*  
September 21, 2021

**WITH A PROJECTED SIGNIFICANT INCREASE OF ELECTRIC VEHICLE OWNERSHIP OVER THE NEXT DECADE, UNIVERSITY OF HOUSTON RESEARCHERS** are working to better understand the infrastructure necessary to support EV adoption, while broadening access to new electric mobility technologies.

Led by UH and funded by a \$150,000 grant from the National Science Foundation Smart and Connected Communities (S&CC) program, the collaborative project brings together METRO, commercial EV charging companies, rideshare partners and the community to analyze strategies to support EV ownership for low-income families in Houston.

The team will also develop a digital master plan for a smart transit hub to establish an overall context of equitable, smart, clean and safe



electric mobility, according to the lead Principal Investigator Bruce Race, director of the UH Center for Sustainability and Resilience (CeSAR) in the Gerald D. Hines College of Architecture and Design.

“Greater access to new technologies requires reduction in economic barriers to EV ownership and transportation services. Communities need to proactively plan for transportation technologies to improve the lives of low-income communities while lowering emissions, increasing transit use, and reducing congestion,” said Race.

The NSF’s Smart and Connected Communities program supports integrative research that addresses fundamental technological and social science dimensions of smart and connected communities.

“The shift to battery power will only pick up pace from here, so cities need to be prepared to react and

adapt to the evolving infrastructure needs that will be necessary to make this transition as smooth as possible,” according to Ramanan Krishnamoorti, UH chief energy officer and the project’s Co-PI.

The project team also includes from UH: Driss Benhaddou, professor of computer engineering technology; Vikram Maheshri, associate professor of economics; Aron Laszka, assistant professor of computer science; and Kimberly Williams, METRO’s chief innovation officer.

Last month, President Biden set a goal for half of all new vehicles sold in the United States by 2030 to be electric-powered. The federal plan also includes establishing a nationwide network of charging stations, financial incentives for consumers to go electric, and financial aid for vehicle manufacturers to support new electric mobility technologies.

—Laurie Frickman



## HABITAT PROJECT RECEIVES TEXAS APA RESILIENCE GOLD AWARD

*Habitat Project Receives Texas APA Resilience Award*  
October 27, 2021

**GERALD D. HINES COLLEGE OF ARCHITECTURE AND DESIGN PROFESSOR BRUCE RACE'S** habitat project, *Robins Landing Town Center: Strategies and Guidance for Resilience*, was recently awarded the Texas American Planning Association (APA) Resilience Gold Award.

This award recognizes a strategy increasing the ability of a community to recover from and adapt to shocks and stresses of natural disasters, human-caused disasters, climate change, and other disasters. The result is the community becomes much stronger and better prepared than ever before.

The idea was born from Race's ARCH 5500 design studio five years ago. Students prepared net-zero concepts for the site and continued to work with Habitat for Humanity and community partners to identify needed services and the kind of 'central place' that draws neighbors together. Robins Landing Town Center was planned as a low impact development (LID), energy-positive, transit-oriented, mixed-use project.

"This is a project that is having real, positive impacts," said Bruce Race, Ph.D., FAIA, FAICP. "Houston Habitat

for Humanity has provided single homes for over 1,000 families. The Robins Landing Town Center will be Houston Habitat's first effort to work with partners to develop a town center providing a social and economic focus."

Located in East Houston, the Robins Landing Town Center project is based on a process organized for collective community action. It has been a catalyst for public, private, nonprofit, and community partnerships meeting pressing community needs, such as healthcare, nutrition, and childcare, that can improve the quality of life for Robins Landing's residents and their East Houston neighbors.

"The project is planned to demonstrate how infill developed can contribute to the creation of energy and detention-positive communities," shared Race. "We are working on making the Town Center an official Houston Resilience Hub that can sustain services during and after weather events. Robins Landing Town Center demonstrates the power of design thinking and, when given the opportunity, how students can influence the future of Houston."

—Destiny Vaquera



**THIS PAGE:** RENDERINGS AND SITE PLANS FOR ROBINS LANDING TOWN CENTER IN EAST HOUSTON





# COMMUNITY DESIGN RESOURCE CENTER (CDRC)

## COLLABORATIVE COMMUNITY DESIGN INITIATIVE

In 2020, the Community Design Resource Center (CDRC) saw the culmination of a twelve-year project. The Collaborative Community Design Initiative (CCDI) has been the CDRC's most impactful and longest running program. Twenty Super Neighborhoods have been part of the initiative and hundreds of community members, students, faculty, and professional experts from across disciplines have participated. CCDI was founded on the principles of interdisciplinary problem-solving, integration of academic and professional voices, community partnerships, and broad-based participation. Community partners take away from the project: (1) a Briefing Book describing their community, including assets and opportunities; (2) multiple opportunities to present their findings to their elected officials and potential partners and funders; (3) access to professionals across disciplines that can assist them in moving the identified projects forward; and (4) a final book publication for each neighborhood.

## 2022 PLACE PLANNING AWARD

The CDRC's submission *Greater Northside Urban Design Toolkit* was the winner of the 2022 Place Planning Award, a recognition bestowed by the national Environmental Design Research Association and its annual Great Places Awards. The Awards seek to recognize work combining expertise in design, research, and practice and contributes to the creation of dynamic, humane places engaging our attention and imagination.

## INTERNATIONAL OSLO ARCHITECTURE TRIENNALE

The CDRC's *Ground UP* submission to the international Oslo Architecture Triennale was accepted for exhibition in the 2022 Neighborhood Index, a catalogue of neighborhood projects, practices, and perspectives. The work exhibited contributes to the Triennale mission: creating more sustainable, diverse, and thriving neighborhoods. The Index explores visionary work from architects, planners, urban practitioners, academics, artists, and activists from around the world. All projects shown in the index were sent in through the international Open Call launched by the Triennale in spring 2022. An international jury selected the submissions to be featured on the online platform, as well as which projects to be exhibited in Oslo during the Oslo Architecture Triennale starting September 22, 2022.



**THIS PAGE:** THE COVER AND PAGES OF THE CDRC'S *GREATER NORTHSIDE URBAN DESIGN TOOLKIT*

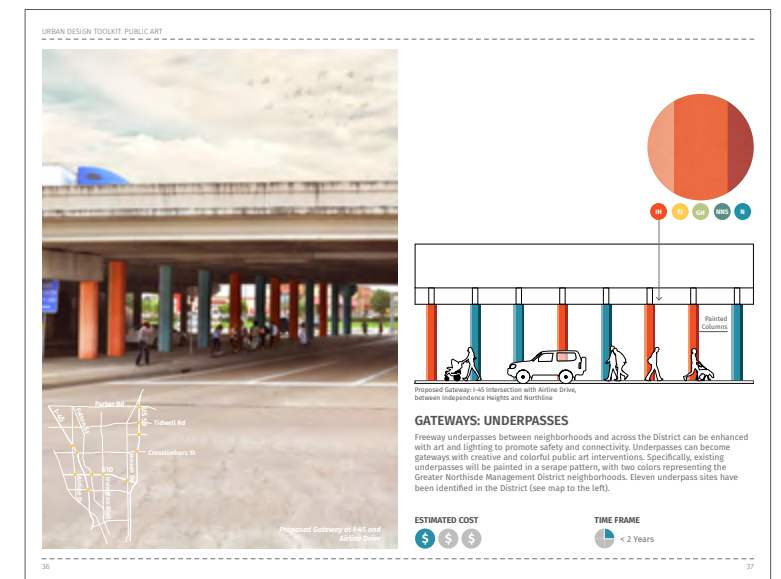





## MATERIALS RESEARCH COLLABORATIVE (MRC)

**OPHÉLIA MANTZ SERVES AS THE DIRECTOR OF THE MRC**, a materials resource for material discovery, innovation, instruction, and research across the College's disciplines, as well as local industry professionals. On-going work of the MRC includes uncovering new and innovative materials, cataloging the physical samples, and researching and inputting data regarding the specific extrinsic and intrinsic properties of these materials. The MRC is also engaged in material research projects funded by grants, gifts, or other sources.

### NEW WEBSITE

The MRC relies heavily on its web-based database of materials. QR codes are assigned to each material, directly linking it to the online database. As technology has changed throughout the years, the database website has not kept up. The College will launch a new MRC website in fall 2022.

## CONSTRUCTION ROBOTICS AND FABRICATION TECHNOLOGY (CRAFT) LAB

**THE HINES COLLEGE CONTINUES TO BE A HAVEN FOR KNOWLEDGE, INNOVATION, AND DISCOVERY.** The construction of the College's new Construction Robotics and Fabrication Technology (CRAFT) Lab is currently underway thanks to the generosity of Gerald D. and Barbara Hines. The lab will serve as a world-class research facility, drawing talented students and faculty to the University of Houston in pursuit of more sustainable and innovative architecture and design. As a home for cutting-edge advanced digital technologies, including construction robotics, full-scale 3D printing, and augmented/virtual realities, among many others, the lab will be a leading center for emerging technologies in Texas, and one of the top facilities in the world.

**ABOVE:** IN 2020, THE COLLEGE COMPLETED CONSTRUCTION ON PHASE I OF THE CRAFT LAB, WITH HOPES OF SEEING PHASE II COME TO FRUITION BY THE END OF 2022.



Experience and engagement in the lab will prepare students from across all the College's disciplines – architecture, interior architecture, and industrial design – to be leaders in trending technologies, increase industry partnerships advancing the Hines College, and enable faculty to pursue influential ground-breaking research.

The mission of the CRAFT Lab supports the Hines College as it pursues innovative research in design and fabrication technologies. The College values the critical engagement of technology in contemporary design and architecture, and looks for ways new technologies can augment how we design, build, and live.

The way objects, spaces, and buildings are designed and made is undergoing a rapid transformation. We must find ways to make the built environment more sustainable while simultaneously making it more resilient to change. Also, new technologies such as artificial intelligence and automation create both new opportunities and challenges to the way we currently operate. Like the wave of innovation during the mid-20th century, we are presently experiencing the beginning of the next industrial revolution. Architects and designers' roles and the related industries of manufacturing and construction are rapidly changing and challenged to be more sustainable and productive.

## DEFINING OUR GOALS

### WORLD-CLASS RESEARCH FACILITY

To create the most advanced center for emerging technologies used within design, architecture, and construction in Texas and one of the world's top facilities. The equipment, processes, and knowledge available at the lab will be a beacon of innovation for the University, the city of Houston, and the state of Texas.

### UNLEASH CREATIVITY OF THE HINES COLLEGE

To develop robust connections with faculty throughout the industrial design, interior architecture, and architecture programs at the Hines College that will unleash the creative potential of faculty and students producing world-class research.

### SUSTAINABILITY AND EQUITY

To make the world a better place through an intense focus on the sustainability and equity embodied in the materials, technologies, and processes used in literally making the world. We strive to create a more equitable environment supporting equal access to advanced technologies, regardless of background. As part of a public institution, the CRAFT Lab pursues research benefiting the public good

through making high-quality architecture and design more accessible, safer, and in solidarity with the natural world.

### INDUSTRY PARTNERSHIPS

To partner with regional, national, and international industry, academic, and public partners in collaborative research projects expanding the capacity and network of the Hines College. The CRAFT Lab acts as a research hub bringing together multiple disciplines within the University of Houston to explore innovative technologies and processes helping our community.

### POST-PROFESSIONAL GRADUATE RESEARCH PROGRAMS

To establish a well-funded and active post-professional program for students pursuing world-class research and making the Hines College a recruitment hub for the future professional and academic leaders.

### INNOVATIVE FACULTY RECRUITMENT

To attract, retain, and assist the most innovative faculty, students, and researchers, and collectively produce research projects at the forefront of design technologies.

**OPPOSITE PAGE:** THE CRAFT LAB NOT ONLY SERVES AS A SPACE TO CREATE AND MANUFACTURE, BUT IT IS ALSO A SPACE FOR RESEARCH AND INNOVATION



## OUR AMBITIONS

### CONSTRUCTION-SCALE ADDITIVE MANUFACTURING

- 3D Printing with clay, adobe, biomaterials, and “green” concrete
- Investigating Circular Lifecycle of Plastics to be able to recycle plastics into new parts.

### FROM MODEL TO WORKING PROTOTYPES

- 3D Printing in final materials that mechanically perform rather than creating only
  - visual representations

### ADVANCED DOCUMENTATION, ANALYSIS, AND VISUALIZATION

- Use LIDAR and Photogrammetry with drones and mobile robotics to better capture real-world site conditions
- Use Real-time Visualization tools to design, visualize, and interact with complex projects using augmented reality and virtual reality environments

### RESEARCH AREA 4: ROBOTIC OFF-SITE CONSTRUCTION

- Onsite construction is dirty, dangerous, and difficult. How can more buildings be

autonomously built in more controlled and safer conditions?

### RAPID DESIGN AND FABRICATION TEAM FOR EMERGENCY RESPONSE

- The CRAFT Lab would be equipped with everything needed to help local and regional communities respond to natural or human-made disasters. With one of the largest populations of designers in the United States, our students and faculty are motivated to use their skills to help our communities.



# designLAB

## CENTENNIAL PLANNING

designLAB has been hard at work visioning and bringing to fruition updates to campus that will grace the University of Houston main campus as it journeys toward its Centennial Year in 2027.

New gateway monument markers will ultimately welcome faculty, staff, students, and visitors to campus. The first gateway is currently under construction at the entry of the new Tilman J. Ferritta Family College of Medicine.

The new University Drive proposal is meant to limit the amount of traffic, returning the major thoroughfare into a pedestrian-friendly promenade.

**BELOW:** A RENDERING OF THE GATEWAY MONUMENT TO THE COLLEGE OF MEDICINE; THE NEW UNIVERSITY DRIVE PROMENADE







# CAREER DEVELOPMENT

IN 2022, THE HINES COLLEGE hosted its largest career fair to date with:

**51**

EMPLOYERS

**82**

JOB POSTINGS

**1,788**

APPLICATIONS

**357**

SCHEDULED INTERVIEWS

**THIS SPREAD:** THE COLLEGE WORKS WITH THE UH ARCHITECTURE AND DESIGN ALUMNI ASSOCIATION TO EXPAND THE NETWORK OF UH GRADUATES ACROSS THE PROFESSIONAL FIELD DURING ITS ANNUAL FAIR.



## PARTICIPATING COMPANIES

- 4b Technology Group, LLC
- Asakura Robinson
- Benjamin Johnston Design LLC
- Blueline
- Boucher Design Group
- Brave / Architecture
- Brochsteins Inc.
- BRW Architects
- CannonDesign
- Corgan
- Cornerstone Architectures, LLP
- Creative Blinds
- DLR Group
- Element Architects
- EYP Inc.
- FGM Architects Inc.
- Gensler
- GLMV
- Goree Architects
- Harrison Kornberg Architects
- HDR
- HKS Inc.
- Hok
- House & Robertson Architects, Inc.
- Huitt Zollars
- Humphreys & Partner Architects
- IBI Group (Texas IBI)
- Jacobs
- Kendall/Heaton Associates
- Kirksey Architecture
- McLemore Luong Architects, LLC
- Meeks + Partners
- Method Architecture PLLC
- Page Parkhill
- PBK
- Perkins + Will
- Perry Homes
- Pflugler Architecture
- PGAL
- PhiloWilke Partnership
- PlanNorth Architectural Co.
- RDLR Architects
- Smith and Co. Architects
- Stantec
- STG Design
- SWA Group
- THR3R Design
- W Partnership, Inc.
- Wold Architects and Engineers
- Worrell Design Group
- Ziegler Cooper



# NEW SCHOLARSHIPS

IN THE LAST YEAR, the College has added five new endowed student scholarships:

- Gensler UH Alumni Endowed Scholarship, 2021
- Tomorrow's Architect Scholarship Endowment, 2021
- Hines Alumni Association Endowed Scholarship, 2021
- Joe Mashburn Memorial Endowed Scholarship for Applied Design, 2021
- Thomas McCarthy - Page Southerland Page Foundation Endowed Graduate Scholarship 2022

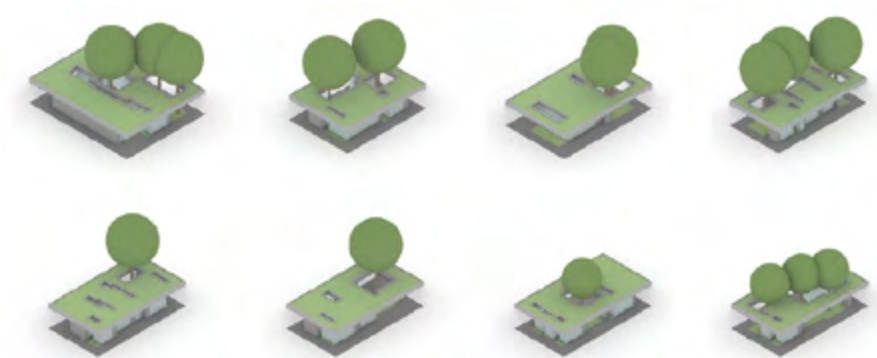

**THIS SPREAD:** STUDENT WORK AND THEIR PORTFOLIO ARE COMPONENTS OF THE COLLEGE'S SCHOLARSHIP APPLICATIONS





# FACULTY

## NEW FACULTY HIRES

ASSISTANT PROFESSOR OF INTERIOR ARCHITECTURE (FALL 2022)

Dijana Handanovic, M.Arch '15

ASSISTANT PROFESSOR OF INTERIOR ARCHITECTURE (FALL 2022)

Ophélie Mantz

ASSISTANT PROFESSOR OF INDUSTRIAL DESIGN IN HEALTHCARE INNOVATION (FALL 2022)

President's Frontier Faculty Search

Elham Morshedzade

President Khator awarded the Hines College a Presidential Frontier Faculty grant to hire an additional faculty member in the area of Healthcare Innovation. The position is shared 75% Architecture and 25% Engineering and allows the College to venture further into healthcare product design in the world's largest medical center.

ASSISTANT PROFESSOR OF URBAN DESIGN IN SUSTAINABLE COMMUNITIES AND INFRASTRUCTURE (FALL 2022)

President's Frontier Faculty Search

Dalia Munenzon

President Khator awarded the Hines College a Presidential Frontier Faculty grant to hire an additional faculty member in the area of Sustainability. The position is shared 75% Architecture and 25% Engineering, allowing the College to secure a critical mass of faculty to deliver the core requirements for a Master of Science degree in Urban Design.

KEELAND LAB DIRECTOR + ASSISTANT/ASSOCIATE PROFESSOR (FALL 2022)

Provost's Key Initiative Search

TBA

In 2021, Provost Short awarded the College a "Key Initiatives" award, opening a search for the new inaugural faculty Director of the Keeland Design Exploration Lab, a new Research Liaison Officer staff position, and two Graduate Assistant student positions to advance the Design/Build program.



TOP TO BOTTOM:

ELHAM MORSHEDZADE AND

DALIA MUNENZON

ASSISTANT PROFESSOR, HISTORY, THEORY, + CRITICISM (FALL 2021)

Deepa Ramaswamy

ASSISTANT PROFESSOR, ARCHITECTURE DESIGN FOR ENVIRONMENTAL SYSTEMS (FALL 2020)

Mili Kyropoulou

## NEW FACULTY BOOKS



Tom Diehl – *Internal: Developing Informed Architectural Languages*



Marta Rodríguez – *Charlotte Perriand @ Kazuyo Sejima: Una revolución sutil*



J. Kevin Story – *The Complexities of John Hejduk's Work: Exorcising Outlines, Applications, and Angels*

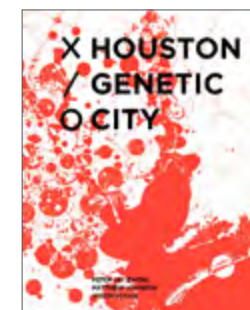

Matthew Johnson, Jason Logan, and Peter Jay Zweig – *Houston: Genetic City*



Gail Peter Borden and Peter Jay Zweig – *City of Refugees*







# FACULTY RECOGNITION AND AWARDS

## RAFAEL BENEYTEZ-DURAN

- Prof. Beneytez-Duran's article, "Contingency In Architecture: Temporal And Technical Ecology As A Medium Towards Equilibrium" will be published in the book *Resilient Communities and the Peccioli Charter: Towards the Possibility of an Italian Charter for Resilient Communities*. Publisher: Springer, Editors: Maurizio Carta, Maria Perbellini and J. Antonio Lara-Hernandez.
- Prof. Beneytez-Duran's article, "Air: From bodies to breathable skins" was published in the journal *CENTER 23: AIR*, University of Texas Austin, *Center for American Architecture and Design Journal*, December 2020.
- Prof. Beneytez-Duran has been working on the Master Plan of Park of Martyrs, Huesca Spain. 2014-2021 – Prof. Beneytez-Duran has designed a Monument of the Spanish Civil War at the Park of Martyrs, Huesca Spain. The project was completed in Spring, 2021.
- Prof. Beneytez-Duran's project, Monument and Master Plan for the Part of the Martyrs," was accepted to the 2021 BEAU SV, Bienal Espanola de Arquitectura y Urbanismo.
- Prof. Beneytez-Duran's was invited to give his lecture, "Mirrors and Balloons," at the Escuela Tecnica Superior de Arquitectura de Madrid.
- 2021-Present- Prof. Beneytez-Duran has served on the Scientific Committee of Fundación Alejandro de la Sota for the Culture Spain Government and CSCAE.
- In the design magazine, *Diseno Interior* Issue 334, December issue, Mercedes Pelaez, director of the section *De Alumnos a Maestros* (from Students to Professors) interviewed Professor Beneytez-Duran. The interview focuses on the work of his and Ophelia Mantz' office and is selected for the last edition of Open House.
- Rafael Beneytez-Duran and Peter Zweig co-designed the installation, *Airscapes* for the 75<sup>th</sup> Anniversary Gala of the college.

- Prof. Beneytez-Duran was a visiting critic at Texas A&M University, October, 2021.
- Prof. Beneytez-Duran was featured in the design magazine, *Diseno Interior*, Issue 346, "Airscapes" 4 pages.
- Beneytez-Duran, Rafael, García-German Javier: "Airscapes" Ed, Park Books Switzerland 2020 IN PROGRESS
- **2018–Present** Beneytez-Duran, Rafael. With C. Taylor, S. Larson, C. Bauer, I. Elola, K, Wilkinson: "Scape Collective Manifesto: Situated Knowledge in Local Matters and Global Conditions" Ed, Trinity Press IN PROGRESS
- **2017–Present** Beneytez-Duran, Rafael, "Atmósfera", Ed, Nobuko, Argentina 2018 IN PROGRESS
- **2021** *Airscapes* #1 Central Piece and Exhibition for the Gala in celebration of the 75<sup>th</sup> Anniversary of the Gerald D. Hines College of Architecture and Design Gala. In collaboration with Peter Zweig.

## GAIL PETER BORDEN

- "Learning in the Time of Coronavirus," by Anastasia Calhoun and Andrew Hawkins, *AIA*, Sept./Oct. 2020 issue.

- Professor Borden was a guest lecturer in the University of Memphis lecture series. He spoke on "New Essentialism: Material Architecture."
- Prof. Borden lectured on his book, *New Essentialism*, at the University of Memphis, October, 2020.
- Landscape Architecture + Architecture titled, "Prototypes for a Real Utopia," December, 2020.
- Gail Borden and Peter Zweig presented "City of Refugees: A Search for Utopia," at the AIA Los Angeles "Design for Dignity" conference, June 24-25, 2021.
- Gail Borden and Peter Zweig gave a lecture for Urban NXT titled "City of Refugees: A Search for Utopia" in Germany, February, 2021.
- The exhibition *City of Refugees* recently opened at Aedes Architecture Forum in Berlin, Germany, alongside world-renowned activist and artist Ai Weiwei's *Purgatory*. *City of Refugees*, led by Hines College faculty members Peter Jay Zweig, FAIA, and Gail Peter Borden, FAIA, and including the work of three years of student studios, is a project of the College that is truly extraordinary! The interactive exhibition integrates augmented

- reality bringing it to life and allowing viewers to experience the exhibition beyond the physical models.
- An accompanying *City of Refugees* book creates an immersive and interactive experience through the use of augmented reality layered throughout the traditional print publication. The book was published by AR + D Press.
- Prof. Borden was an invited juror at the University of Western Australia, Perth for the Architecture program there.
- Prof. Borden was invited to attend the final jury at the University of Memphis.
- Prof. Borden contributed a book chapter, "Glimpses, Revelations and Accompaniment," for *VERUM FICTUM*, Culicidae Architectural Press.
- Professor Borden published "City of Refugees" Right to the City in *Topos Magazine* #115 The International Review of Landscape Architecture and Urban Design, June, 2021
- Prof Borden published his article "Untitled Panels" in *Frost Tower Art Collection Catalog*, June, 2021.
- Prof. Borden gave a lecture on the "City of Refugees" at the

- Design with Dignity conference, AIA, Los Angeles.
- Prof. Borden was a guest lecturer at the University of Memphis. His lecture, "Professional Practice: Borden Partnership" focused on his professional practice.
- Prof. Borden served on the AIA Houston Chapter Board of Directors.
- Prof. Borden and Peter Zweig designed three Mobil pavilions for the Museum of Fine Arts Houston.
- Prof. Borden's exhibition, "Drawing Attention," was exhibited at the Roca London Gallery.
- Prof. Borden and Peter Zweig received an AIA Houston Design award for their "Non-Pavilion" for the Museum of Fine Arts Houston.
- Prof. Borden completed two large installations of his art for prominent permanent collections in Dallas, private clients.
- Prof. Borden's solo show, "Spaced," was exhibited at the Galleri Urbane, Dallas, TX, October, 2021.



- Prof. Borden's book: *Principia: Architectural Principles of Material Form*, co-authored with Brian Andrews, Chinese Edition: Tianjin University Press, November, 2021.z
- Prof. Zweig and Gail Peter Borden were featured in an article by Wojciech Czaja, "City of the Stateless," *TOPOS Magazine*, Europe, November, 2021.

### **GEOFFREY BRUNE**

- Prof. Brune published a limited edition book, *Boneyard Bits*, describing the environmental consequences of 100 years of dredging at the port of Brunswick, Georgia,
- Prof. Brune published a limited edition book, *Fallen Falling*, Exploring North, South and West Boulevards, Houston.

### **ALAN BRUTON**

- Prof. Bruton published a book chapter, "Salon, an Autonomous Ludic Interior" in the book "Interior Provocations, History, Theory, and Practice of Autonomous Interiors", Routledge Press, Fall 2020.
- Prof. Bruton published a book chapter, "Airplayers and Beyond, a Conversation with Sara

Garden Armstrong" in the book *Sara Garden Armstrong ,Threads and Layers*, Great Jones Press, Spring 2021.

- Prof. Bruton's board game "Salon, a game of Table & Chairs" was awarded in two categories in the International Design Awards (IDA): Bronze Award in Design for Society Category- Design for Social Impact Gold Award in Toy Design Category - Board and Card Games.
- Prof. Bruton moderated "Sally Walsh Round Table" Spring, 20/21 CoAD Lecture Series "Matter(s)": Alan Bruton, Stephen Fox, Lois Farfel Stark.

### **GEORGE CHOW**

- Prof. Chow received the 2021 Industrial Designers Society of American (IDSA) Young Educator Award. This is a national award with only 1-3 recipients selected in each year.
- Prof. Chow's article, "The Changing Face of ID Education: A Roundtable with IDSA Educators," was published in 2021 *Innovation Magazine: Academia* 360, pp 14-17.
- Prof. Chow's paper, "Trash to Treasure: An Upcycling Project Case Study," was presented

at the IDSA Conference: Explorations in Design Education.

- Prof. Chow was elected as the 2021-2022 IDSA Southern District Representative.
- Prof. Chow is a member of the IDSA Houston Professional Chapter Planning Team.
- George Chow was selected to chair a paper presentation session at the Interdisciplinary Practice in Industrial Design (IPID) Conference, an affiliated conference of the Applied Human Factors and Ergonomics (AHFE) Conference in Manhattan, NY July 25-29, 2021. His session was called "Explorations in Design Education" and he invited 5 other presenters from various ID schools to present in it. He presented his paper called "Trash to Treasure: An Upcycling Project Case Study."

### **JOE COLACO**

- Professor Colaco was interviewed for ABC Channel 13 news on the collapse of the Surfside Champlain South condominium towers in Florida, as an expert witness.
- Prof. Colaco was interviewed for KPRC Channel 2 news on the

collapse of the Surfside Champlain South condominium towers in Florida, as an expert witness.

- Prof. Colaco was interviewed, in Spanish, for Telemundo Channel 3007 news on the collapse of the Surfside Champlain South condominium towers in Florida, as an expert witness.
- Prof. Colaco was interviewed, in Spanish, for Telemundo radio news on the collapse of the Surfside Champlain South condominium towers in Florida, as an expert witness.
- Prof. Colaco was interviewed by Craig Cohen for Houston Matters radio on the collapse of the Surfside Champlain South condominium towers in Florida, as an expert witness.

### **CURTIS DAVIS**

- Prof. Davis has undertaken PRH Preservation – Program Development/Master Planning and Fund Raising for 24-unit shot-gun house community on a single block.
- Row House CDC – Program development and fund raising for 17-unit duplex and accessory dwelling unit expansion of existing development on Francis St. in Houston's Third Ward.

- Program Development and Master Planning for community mixed-use developments on Emancipation Ave. and Holeman Streets in Houston's Third Ward.
- Third Ward Project Row Houses – Program Development and Strategic Implementation Plan for the Emancipation Community Development Partnership initiative.
- City of Houston – Preliminary contract award as sub-contractor to Reinvestment Fund's Market Value Assessment (MVA) for Housing and Neighborhood Commercial Corridors in Houston, TX
- Prof. Davis received a Certificate of Recognition from the City of Houston for the Northern Third Ward Implementation project.
- Prof. Davis is a Coordinating Board Member of the Houston Housing Collaborative.
- Prof. Davis is a member and sub-committee Chairperson of the Houston/Harris County Housing Stability Task Force.
- Prof. Davis is a Liveable Places Committee member of the Houston Planning Commission.

### **TOM DIEHL**

- Prof. Diehl's book, *Internal: Developing informed Architectural Languages*, was published by Applied Research and Design Publishing, October, 2021.

### **DIETMAR FROEHLICH**

- Prof. Froehlich participated on a panel discussing the revolutionary architect of the Frankfurt Kitchen: Margarete Schutte-Lihotzky. Eggersmann Houston hosted the film presentation and panel. Joining Dr. Froehlich was interior Designer Anne Breux, and Interior Designer Marie Flanigan. The panel was moderated by *Modern Luxury Interiors Texas* publisher Jennifer Cope.
- Prof. Froehlich, with Cara Murray, Editors, *Projections*, Houston Atrium Press, ISBN: 978-1-946045-26-3.
- Professor Froehlich wrote a book chapter, "Megacities: Fiction, Hyperreality, Future," for *Informality and the City*, Springer Nature, Rotterdam, 2022.



## JEFF FENG

- Prof. Feng delivered a keynote address at the kick-off meeting of the I-CARE Project (Innovation and Commercialization for an Agile and Resilient Ecosystem).
- Prof. Feng is the Project Investigator for the Subaward grant to UH. He is lecturing on innovation and business. He also led several training workshops and provided design and business mentorship to startups at the University of Puerto Rico Innovation Center.
- Prof. Feng represented the ID program at the SXSW Conference/Exhibition in March in Austin.
- Niell Gorman, Jeff Feng, Shirley Yamilet, and Marin Pareja's paper, "Enhancing Prosthetic hand Functionality with Elastic 3D-Printed Thermoplastic Polyurethane," was presented at the Human Factors and Ergonomics in Healthcare and Medical Devices, AHFE 2021 Conference.
- Tristan Bennett, Jeff Feng's paper, "Establishing a Relationship Between VOMS Performance and Changes in EEG Signatures for a Rapid Assessment and Diagnosis of Concussions," was presented at the Human Factors and Ergonomics in Healthcare and Medical Devices AHFE 2021 Conference.
- Niell Gorman, Antoinette Louw, Alex Craik, Jose Gonzalez, Jeff Feng, and Jose L. Contreras Vidal's paper, "Design Principles for Mobile Brain-Body Imaging Devices with Optimized Ergonomics," was presented at the AHFE 2021 Conference in Advances in Usability, User Experience, Wearable and Assistive Technology.
- Prof. Feng's paper, "A Fusion of Service, Technology, and Environment: An Interdisciplinary Experimentation Through Participatory Community Design," was accepted for the Fifteenth International Conference on Design Principles & Practices. This was a joint studio with Interior Architecture.
- Prof. Feng developed a Extralight Power Grove Horticulture Folding LED in 2021.
- Prof. Feng received the Sprint-ICARE Award Grant by the Economic Development Administration (EDA). This grant was won in collaboration with the University of Puerto Rico Innovation and Commercialization for an Agile and Resilient Ecosystem.
- Prof. Feng's paper, "Optimizing Sources of Inspiration for Innovation: A Case Study in Concept Generation Process," was published in the Design Research Society 2020 International Conference proceedings, Brisbane, Australia, August 2020.
- Prof. Feng was Chair of the IDSA Houston Chapter.
- Prof. Feng has been appointed to the Editorial Review Panel for the *JASE (Journal of Applied Science and Engineering)*.
- Prof. Feng has been selected to be on the Editorial Review Panel for the *International Journal of Design Education*.
- Prof. Feng filed a Provisional IP Application for his "EEG Headset for BCI Applications," 2021.
- David, E., Feng, Jeff, "Upper Limb Prosthesis Development," 2021.
- Prof. Feng received IDSA's 20/21 Recognition. Chosen by IDSA Staff and confirmed by At-Large Director of Awards ClayVon Lowe, IDSA, the 20/21

Recognitions highlight 20 Professional, Young Professional, and Affiliate members who dedicated their time and talents this year to the betterment of our Society and advancing the industrial design profession through information, education, community, and advocacy.

- Prof. Feng was elected as a Senior Member of the National Academy of Inventors, Class of 2022. NAI Senior Members are active faculty, scientists, and administrators from NAI Member Institutions who have demonstrated remarkable innovation producing technologies that have brought, or aspire to bring, real impact on the welfare of society. They also have growing success in patents, licensing, and commercialization, while educating and mentoring the next generation of inventors.
- David E. and Jeff Feng's, "A Novel Headset System synchronizing Vision and EEG Testing for a Rapid Assessment and Diagnosis of Concussions and Other Brain Injuries," was presented at the International Conference on Applied Human Factors and Ergonomics and published in the proceedings, 2022.

## STEPHEN FOX

- Prof. Feng's article, "Efficacy in Synergistic Innovation: Managing Co-creation Design in An Interdisciplinary Studio," was published in the *International Journal of Design Education*, 2022.
- Niell G., David, E., and Jeff Feng's article, "The Development of a 3D-printed Prosthesis," 2022.
- Alex, C. Jose G., David E., J. Feng., and Contreras, V.J., "The Development of a Brain-controlled Upper-Limb Robot-Assisted Rehabilitation Device for Stroke Survivors," 2022.
- *Making Houston Modern: The Life and Architecture of Howard Barnstone* was published by the University of Texas Press. It was edited by Barrie Scardino Bradley, Stephen Fox, and Michelangelo Sabatino. Professor Emeritus Bruce Webb contributed a chapter to the book as well.
- Stephen Fox's article "Gerald D. Hines, 1923-2020" was published in *Texas Architect*, November/December issue, Of Note, p. 18-20.

- Professor Fox contributed chapters to *Avant Garde in the Cornfields: Architecture, Landscape Architecture and Preservation in New Harmony*, edited by Michelangelo Sabatino and Ben Nicholson.
- David Heymann and Stephen Fox have published their book, *John S. Chase: The Chase Residence*, Tower Books Imprint, UT Austin, November 2020.

## MICHAEL GONZALES

- Prof. Gonzales received the Hispanics in Philanthropy's PowerUp Fund Grant. In 2021, Google.org made a \$3M grant to Hispanics in Philanthropy's PowerUp Fund. Together with Ureeka—a community built to support and grow underrepresented small businesses—the PowerUp Fund is not only helping grow Latinx small businesses, but also helping entrepreneurs build skills to continue that growth in the future. On December 10th, HIP, Google.org, and Ureeka announced the 500 grantees receiving capital and mentorship from the PowerUp Program throughout Texas, California, and New York.



- Microsoft Headquarters invited Permanent Installation by DS+R and Lumiere Group, Redmond, WA. In collaboration with Shane and Peter Allbritton.
- Davita Headquarters, Permanent Installation, Denver, CO, In Collaboration with RE:Site.
- Sky Scrolls, Public Art Project, Funded by Art League Houston – installations In Collaboration with Erika Blumenfeld & Flying Carpet Creative.
- Engram, Permanent Installation, TAMU EnMed Building, Houston, TX, in Collaboration with Shane and Peter Allbritton.
- Forge for Families, Design Optimization and Digital Fabrication Workflow for Custom Panelized Interior, Houston, TX.
- Lycee Francais de San Francisco, Design Optimization and Digital Fabrication Workflow for Custom Panelized Exterior Façade, San Francisco, CA.
- The Fay School, Design Optimization and Digital Fabrication Workflow for Custom Panelized Interior, Houston, TX.

- Meg Jackson and Michael Gonzales had a paper accepted for the National Conference on the Beginning Design Student: “Algorithmic Thinking in the Beginning Design Process.”
- Jackson, M., and Gonzales, M., “Pattern Performance.” In *Space Within and Around*, edited by Weiling He, China Architecture and Building Press, 2022 (Expected)

### JESSE HAGER

- Jesse Hager’s firm Content Architecture won a Texas Society of Architects 2022 Design Award.

### JEFFREY HALSTEAD

- Jeffrey received one of eight artists to be awarded MacDowell Colony residencies for 2021. He is the first of the MacDowell residents to be a Virtual MacDowell – participating digitally and then receiving a choice of physical residencies once the pandemic is over. He joins others from six different disciplines. The residency has existed since 1907.

### DIJANA HANDANOVIC

- Prof. Handanovic and seven undergraduate Architecture students joined forces with Houston’s Awty International School and non-profit organization Schools for Children of the World (SCW) to raise money and build a new school in a rural Buenos Aires village, fifteen miles from Comayagua, Honduras. SCW and Awty International students raised more than \$23,000, with the total cost of construction for the project estimated to be \$22,000.
- Prof. Handanovic took on the restoration and importing of the Kiosk K67, Slovenian architect-designed Kiosks from 1966 that received world-wide attention for its clever modular design. It became a symbol of Yugoslavia.
- Prof. Handanovic’s book chapter, “Informalizing Yugoslavia”, in *Informality and the City: Theories, Actions, Interventions*, forthcoming publication 2022.
- Prof. Handanovic’s book chapter, “Past Futures. The Collective Consciousness of Yugoslav Brutalism,” in the *Interior Reader Theory Reader*, forthcoming publication 2022

### MEG JACKSON

- Meg Jackson has had two papers accepted for the National Conference on the Beginning Design Student: “Prioritizing Design Behaviors: Establishing Studio Culture in Online and Hybrid Studio Formats,” and, with Michael Gonzales: “Algorithmic Thinking in the Beginning Design Process.”
- Jackson, M., and Gonzales, M., “Pattern Performance.” In *Space Within and Around*, edited by Weiling He, China Architecture and Building Press, 2022 (Expected)

### DANIEL JACOBS

- Daniel’s paper, Curriculum for Climate Agency: Design (in)Action, was accepted for presentation on a panel titled “Monstrous Infrastructure: The Alternative Scales of Production” He presented a design and research project called PALM-HOUSE investigating the relationships between natural ecosystems, material commodities, and ecological care in the form of several experimental structures designed to care for a specific and very special palm tree at the ACSA/EAAE Teachers Conference in June.

- Daniel presented a proposal for a mobile pavilion design for Mexico City called INSTANT-NATURE, a learning center for plant care and ecosystem maintenance to the 27th World Congress of Architects, UIA RIO in July.
- Jacobs, Daniel and Brittany Utting. “The Difficult View.” Plat 10.0: Behold, 2021.
- Jacobs, Daniel and Brittany Utting. “HOT-WALL: A Simple Machine.” *POOL: Plant*, Issue 6, 2021. 34-35.
- Jacobs, Daniel and Brittany Utting. “Peace, Commerce, Friendship: A Portrait of a Palm.” 2021 ACSA/EAAE Teachers Conference: Curriculum for Climate Agency, Association of Collegiate Schools of Architecture and European Association for Architectural Education, 2021.
- Jacobs, Daniel and Brittany Utting. “Blockchain Ecologies: Ownership Beyond Extraction.” *MIT Thresholds 50: Before // After*, Spring / Summer 2022.
- Jacobs, Daniel and Brittany Utting. “HOT-WALL: From Trending Tropicals to Technologies of Care.” *ARQ 108: Vegetation*, September 2021. Pg. 82-89.

- Jacobs, Daniel and Brittany Utting. “Forest Commons: From Carta de Foresta to Blockchain Sovereignty.” *The Avery Review*, February 2022. Online.
- HOME-OFFICE. “FIELD-STATION.” The Weil Project Wall, The Sam Fox School of Design & Visual Arts at Washington University in St. Louis, MO, Solo Exhibition, 2022
- HOME-OFFICE. “OFFICE-PARTY.” Work Processes in Architecture. Curated by Kadambari Baxi and Klaus Platzgummer. Architekturmuseum der Technischen Universität Berlin (TU Berlin), Berlin, Germany, Invited Group Exhibition, Mar - May 2022.
- HOME-OFFICE. “OFFICE-PARTY.” A Section of Now: Social Norms and Rituals as Sites for Architectural Intervention. Curated by Giovanna Borasi. Canadian Centre for Architecture (CCA), Montreal, Canada, Invited Group Exhibition, 2021-2022.



## MATT JOHNSON

- Prof. Johnson and Michael Kubo’s “Dialogue on Gulf: Architecture, Ecology, and Precarity on the Gulf Coast,” by Sophie Hollis in *Texas Architect*, May 2021.
- Matt Johnson and Michael Kubo received the 2021 ACSA/Temple Hoyne Buell Course Development Prize in Architecture, Climate Change, and Society for their proposal, “Gulf: Architecture, Ecology, and Precarity on the Gulf Coast.”
- Prof. Johnson, Peter Zweig, and Jason Logan have just published their book, *Houston: Genetic City*. The book was published by Actar Press.

## DONNA KACMAR

- Prof. Kacmar was featured in “Case Study: Rose/Knox Townhouses or Architects Build Cheap House for Themselves,” in Pressman, Andrew, *Professional Practice 101: Business Strategies and Case Studies in Architecture, Third Edition*, NY: Routledge, pp107-115.
- Donna Kacmar was part of a panel at the TxA Convention in October. She was discussing her recent addition to her

house. She was discussing the “dialogue between the private dwelling and community.”

- Prof. Kacmar delivered a paper at the TxA Convention in Fort Worth in October on the subject of “Big Little Hotels.” She shared some of her investigations pertaining to her forthcoming book of the same title.
- Kacmar, Donna and Rogers, Susan with Anne-Elisabeth Baker, Miranda Gonzalez, Jolene Limquenco, and Sarah White. “Design Justice” presented at the national “Design + Diversity” Conference, August 7, 2021 (virtual).
- Kacmar, Donna and Rogers, Susan with Anne-Elisabeth Baker, Miranda Gonzalez, Jolene Limquenco, and Sarah White. “Design Justice” presented at Gulf Coast Green, August 6, 2021 (virtual).
- Prof. Kacmar’s article, “Hotel Histories,” was published in *Texas Architect*, March-April, 2022, pp. 46-51.

## MIN KANG

- IDEA 2022, Industrial Designers Society of America (IDSA) UX/UI Design for Community Communication

and Co-work Platform (submission work-in-progress)

## MARK KIMBROUGH

- Prof. Kimbrough received a \$50K grant from the Farish Fund to support the ID + activities in the Industrial Design program. This fund has allowed ID to attend the SXSW Conference.

## MICHAEL KUBO

- Prof. Michael Kubo and Matt Johnson’s “Dialogue on Gulf: Architecture, Ecology, and Precarity on the Gulf Coast,” by Sophie Hollis in *Texas Architect*, May 2021.
- Prof. Michael Kubo and Matt Johnson received the 2021 ACSA/Temple Hoyne Buell Course Development Prize in Architecture, Climate Change, and Society for their proposal, “Gulf: Architecture, Ecology, and Precarity on the Gulf Coast.”
- Center for Advanced Study in the Fine Arts (CASVA), National Gallery of Art | Publication Grant for *The Idea of Anonymity* [\$5,000]
- Wyeth Foundation for American Art | Publication Grant for *The Idea of Anonymity* [\$2,500]

- Prof. Kubo was an invited lecturer at the Harvard Graduate School of Design on “Discourse and Advocacy in the Spaces of Curation.”

- “Jean Bodman Fletcher.” Pioneering Women of American Architecture lecture series, Philip Johnson Glass House, New Canaan, CT, October 22, 2020. [presented virtually due to Covid-19]

- Dr. Kubo was an invited lecturer at Princeton University School of Architecture on “Stranded Assets: Architecture and Energy Transitions.”

- Dr. Kubo was an invited lecturer and juror for the Advanced Master’s Program Studio at the Escuela Técnica Superior de Arquitectura de Madrid (ETSAM). Lecture was titled, “Lateness,” May, 2021, virtual.

- Prof. Kubo’s peer-reviewed book chapter, “Building Identities: Transnational Exchange and the Authorship of Modern Gulf Heritage.” In Roberto Fabbri and Sultan Al Qassemi, ed., *Urban Modernity in the Contemporary Gulf: Obsolescence and Opportunities*. London: Routledge, 2021, 100– 119.

- Prof. Kubo’s book chapter, “Concrete Ventures: TAC, Pace, and Transnational Exchanges” was published in the Construction of Modern Kuwait.” In Dalal Musaed Alsayer, Ricardo Camacho, Sara Saragoça Soares, ed., *Pan-Arab Modernism 1968-2018: The History of Architectural Practice in The Middle East*, ed. Barcelona: Actar Publishers, 2021.

- Prof. Kubo’s chapter, “Intercontinentalism: TAC in Sharjah.” In Sultan Sooud Al Qassemi, Todd Reisz. *Building Sharjah*. Sharjah: Barjeel Foundation, 2021, 312–315.

- Prof. Kubo’s article, “Sarah Pillsbury Harkness.” Beverly Willis Foundation, *Pioneering Women of 20th-Century American Architecture* biographical series, ed. Mary McLeod and Victoria Rosner, 2021.

- Prof. Kubo was recognized with the Society of Architectural Historians | 2021 Philip Johnson Exhibition Catalogue Award for *Imagining the Modern: Architecture and Urbanism of the Pittsburgh Renaissance* (2021). This is one of the highest honors bestowed by the Society.

- Prof. Kubo participated in a panel discussion on Exhibitionary Order: Display as World View, University of Virginia School of Architecture, CE+ Conversations series, March 26, 2021. [presented virtually due to COVID-19]

- Prof. Kubo participated in a panel discussion on Peter Reyner Banham Fellowship: 20 Years, 21 Banham Fellows Symposium, University at Buffalo School of Architecture, March 6, 2021. [presented virtually due to COVID-19]

- Prof. Kubo’s article, “Genius versus Expertise: Frank Lloyd Wright and The Architects Collaborative at the University of Baghdad.” *Histories of Postwar Architecture*, No. 8: Impatient Cities of the Gulf: Post-oil Architecture in *Flux*, 2022. 2–29.

- Prof. Kubo received a research grant from the Houston Endowment for Architecture’s Temporalities (grant active 2021-22) [\$25,000]

- Prof. Kubo participated in a panel discussion on Project into Practice, Wentworth University, October 14, 2021. With Ann Lui and Craig Reschke. [presented virtually due to COVID-19]



- “Jean Bodman Fletcher.” Beverly Willis Foundation, *Pioneering Women of American Architecture* biographical series, ed. Mary McLeod and Victoria Rosner.
- *The Idea of Anonymity: TAC and the Authorship of Corporate Architecture*. Sole-authored, peer-reviewed book. Proposal accepted, currently in agreement with Birkhauser/De Gruyter to submit full manuscript for peer review in 2022.
- *Futures of the Architectural Exhibition: Conversations on the Display of Space*. Michael Kubo, Reto Geiser, ed. Zürich: Park Books, 2022. Goes to press in early Spring 2022.
- “AEC(OM), Or the Rise of the Multinational Architectural Conglomerate.” *Log 54: Coauthoring*, forthcoming 2022.

## ANDREW KUDLESS

- 2021: One House Per Day, Houses #485 - #491, Online. Prof. Kudless was Invited to design 7 houses for the One House Per Day project by the project’s director, Andy Bruno. The project is an Instagram project found at @one\_house\_per\_day where for the first 365 days Andy Bruno drew all of the houses. For the second year, Bruno has invited

52 architects from around the world to design the next 365 houses. Each speculative house is represented by only 1 plan, section, and axonometric.

- Prof. Kudless’ furniture piece, “Louis Vuitton Objets Nomades” was on exhibit at Design Miami, 2021.
- The “Louis Vuitton Objets Nomades” furniture piece was on exhibit at the Goya Studio, Los Angeles, CA, 2021.
- The “Louis Vuitton Objets Nomades” furniture piece was on exhibit at the K11 Musea, Hong Kong.
- Prof. Kudless’ lecture, “On Growth and Form,” was the keynote address for the Computational Design (CD) Next Conference, March, 2021, Virtual.
- Prof. Kudless was a guest lecturer, “Collaborating with Machines,” at the University of Pennsylvania.
- Prof. Kudless was a guest lecturer, “On Growth and Form,” at the University of Cincinnati.
- Prof. Kudless’ Workshop, “Robotic Drawing for Graphic Designers,” was given at San

Jose State University, San Jose, CA. This was a five day workshop.

- Prof. Kudless received the Chicago Athenaeum American Architecture Award, The American Architecture Awards “honor the best, new significant buildings and landscape and planning projects designed and/or built in the United States and abroad by the most important American architects and planners practicing nationally and internationally.”
- On Growth and Form, Live Academy, Dubai, Fall 2020 Lecture Series of MEAL (Middle East Architecture Lab)
- Prof. Kudless was a guest lecturer, “The Design and Fabrication of Confluence Park,” at the School of Architecture, The University of Texas, Austin.
- “On Commission: Design Miami + Pierre Jouet,” Savannah College of Art and Design, Savannah, Georgia, Presentation and panel discussion with Axelle de Buffévent and Khoi Vo.
- Crypto Cities V1 Workshop hosted by Design Morphine. Workshop for over 160 international students on procedural drawing and NFTs on the blockchain.

## MILI KYROPOULOU

- Prof. Kyropoulou was invited talk in international event: Watch for the Outdoors During a Pandemic: Generative Shading Design for a Warming Climate. Performance Huddle International Building Performance Simulation Association (IBPSA) Houston Chapter, Virtual.
- Prof. Kyropoulou was invited to lecture on “Climate Change and Hospitality: The Role of the Architect and Future Scenarios in Greece.” at the Energy Efficiency Conference. Greece, online, June 30th.
- Prof. Kyropoulou was interviewed for a regional workshop: Urban Land Institute (ULI) Stakeholder Interview/ Focus Group, March 25th.
- Kyropoulou, M., Subramaniam, S., Hoffmann, S., 2021. “An Automated Workflow for Urban Greening Based on Photosynthetic Radiation Modeling.” *Journal of Physics: Conference Series*, 2069, 012060.
- Kyropoulou, M., Huang, J., 2020. “Weather File Creation Methodology for Remote, Underserved Locations.” PLEA Conference Proceedings. A

Coruña, Spain. September 1–3, 2020. Vol. 2. pp. 1089–1094.

- Kyropoulou, M., Shrestha, S., 2020. “Low Source Energy Neonatal Unit in Mbale, Uganda: A whole building assessment in a low resource setting.” PLEA Conference Proceedings. A Coruña, Spain. September 1–3, 2020. Vol. 2. pp. 1321–1326.
- Raffaella Montelli and Prof. Kyropoulou’s paper, “Impact of Climate Change in Houston, TX: Resilient Residential Buildings and Equitable Design,” written with Raffaella Montelli, was accepted to the Architecture Research Centers Consortium – European Association for Architectural Educators 2022 International Conference: Resilient City: Physical, Social and Economic Perspectives, March 2-5 in Miami. ARCC – EAAE 2022 has attracted over 300 participants from 29 countries.
- Prof. Kyropoulou delivered a Webinar on March 22, 2022 titled: “Daylighting Through Time – Concepts and Misconceptions” for the Illuminating Engineering Society (IES) Houston.
- Radiation Modeling,” at the 8th International Building Physics Conference (IBPC) Copenhagen,

Denmark. August 25–27, virtual.

- Montelli, R., Kyropoulou, M., 2022. Impact of Climate Change in Houston TX: Resilient Residential Buildings and Equitable Design. ARCC–EAAE 2022 Conference, Miami, FL. March 2– 5, 2022. – Accepted paper
- BuildSim Nordic 2022, Outdoor comfort in the subtropics: shading design using evolutionary computation. – Accepted abstract paper presentation in international conference. An Automated Workflow for Urban Greening Based on Photosynthetic Radiation Modeling. IBPC Conference, Copenhagen, Denmark. August 25–27, online.
- Prof. Kyropoulou was accepted to participate in a Timber Design Faculty Deveopment Workshop at Clemson University. Travel expenses, lodging and meals are funded through a generous grant from the Softwood Lumber Board.
- Prof. Kyropoulou’s paper, “Outdoor Educational Spaces: Generative Shading Design for a Warming Climate,” was accepted for presentation at the 2022 Building Performance Analysis Conference and SimBuild, co-organized by ASHRAE and IBPSA-USA.



## **RAFAEL LONGORIA**

- Rafael's article, "Ibero-American Houston Experiments," was published as part of *Housing for the 99%*, Illinois Institute of Technology Press, Chicago, IL.
- Prof. Longoria consulted on the "Mexican-American Cultural Center Master Plan" for the Museo Guadalupe-Aztlan, 2021.
- Prof. Longoria was a Jury Member for the Rice Design Alliance Spotlight Award for Emerging Architecture, Rice University, 2019-2021.
- Prof. Longoria is the Co-Editor, *AULA: Architecture @ Urbanism in Las Americas*.
- Jury Member: ACSA College of Distinguished Professors, Fall 2021.
- Longoria, Rafael & Emilio Longoria. "Informality in South Texas: Understanding the Evolution of Colonias in El Cenizo & Rio Bravo," *Informal Cities*, Springer Books, The Netherlands, 2022 (expected).
- Longoria, Rafael & Stephen Fox. "A Brief Architectural History of Mexico City," *Hopeful Rebar: Informal Urbanism in Mexico City*, URBANIA/University of Cincinnati Press, Cincinnati, OH, 2022 (expected).

## **OPHELIA MANTZ**

- Text titled as "Contingency In Architecture: Temporal And Technical Ecology As A Medium Towards Equilibrium" will be published in the book *Resilient Communities and the Peccioli Charter: Towards the Possibility of an Italian Charter for Resilient Communities*. Publisher: Springer, Editors: Maurizio Carta, Maria Perbelliniand, and J. Antonio Lara-Hernandez.
- 2021 / BEAU XV / Bienal Española de Arquitectura y Urbanismo. Project submitted - Plan De Ordenacion Parque De Las Martires, Huesca, Spain.
- Prof. Mantz's article, "From the Forest to the Garden: Praise for a Temporal and Technical Ecology," was published in *ARQ, 108: Vegetation*. The journal is a peer-reviewed and bilingual journal from the School of Architecture of the Universidad Católica de Chile.
- Prof. Mantz's article, "From DIY to the Workshop or the Space of Transformation in France," was accepted for publication by the PpA from the University of Sevilla, Spain.
- PpA25 Emergencias Del Espacio Comun article published

November 2021, p. 86-103.  
Article Title: "Del Bricolaje Altaller O El Espaciode La Transformacion En Francia."  
Bilingual, Spanish-English.

- ACSA "New Instrumentality" Proceedings "Tobogan House: Revisiting the History", published fall 2021.
- 2022 Lisbon Architecture Triennial/ Terra/ Independent work project submitted - "Polipropilair."

## **MARCUS MARTINEZ**

- Prof. Martinez' article, "At the Car Park," was published in *Texas Architect*, 2022, p. 60-63.

## **PATRICK PETERS**

- Prof. Peters was featured in an article, "Architects Expect Big Design Shifts Thanks to COVID-19," in *Houston Press*, by Shaefer Edwards, September 8, 2020.
- Prof. Peters was a guest lecturer, "The GD/BS and Bee Gardens," Econautics Sustainability Institute, Beaumont, TX, September, 2021.

## **BRUCE RACE**

- Dr. Race received a \$1M (\$999,999) National Science Foundation Grant. This is Phase 2 for his project: Artificial-Intelligence-Based Decision Support for Equitable and Resilient Food Distribution During Pandemics and Extreme Weather Events, Civic Innovation Challenge. His team members are: Ioannis A. Kakadiaris, Computer Science, Hiba Baroud, Vanderbilt University, Aron B. Laszka, Computer Science, and Casey Durand, UT Health Science Center.
- Prof. Race won a 2021 American Planning Association Texas Chapter Gold Resiliency Award for his project: "Robins Landing Town Center: Strategies and Guidance for Resilience." The award recognizes a strategy that increases the ability of a community to recover from and adapt to shocks and stresses (natural disasters, human-caused disasters, climate change, etc.), resulting in it becoming stronger and better prepared than ever before.
- Prof. Race led an interdisciplinary team in the HINES ULI URBAN COMPETITION. His team became a finalist with a \$10,000

award. Students: Jie Yang (Team Leader), Master of Architecture in Sustainable Urban Systems, University of Houston  
Hillary Telegrafo, Bachelor of Architecture, University of Houston  
Jose Medina, Masters of Business Administration (MBA), University of Houston  
Yiru Zhang, Masters of Landscape Architecture, The Pennsylvania State University  
Wenjuan Li, Masters of Urban Design, Columbia University.  
Academic Advisors: Dr. Bruce Race, FAIA, FAICP, Director of Sustainability and Resilience (CeSAR), University of Houston  
Keith Richards, MBA Real Estate Development Program Director, University of Houston  
Professional Advisors: Tiger Lyon, Associate, Gensler.

- Prof. Race presented his paper, "Climate and Energy Positive Infill Development" (2021). American Planning Association APAC3 • 21 Cross Chapter Conference (AR, MO, NM, OK, TX). Ft. Worth, TX.
- Dr. Race was the PI for the (2021). NSF SCC-PG: Pilot for Equitable Electric Mobility: Smart Charging, Smart parking, and METRO Pass System. National Science Foundation. \$150,000.

- Dr. Race was the Co-PI for the 2021 NSF SCC-CIVIC-PG Track B: Equitable Food-Security: Disaster-Resilient Supply Chains for Pandemics and Extreme Weather Events. National Science Foundation. \$50,000.
- Dr. Race is serving on the Resilient Design Assistance Team. Houston One Voice (HOV). 501c-3 Formation Board, Ex-Officio. (2018-present). [houstononevoice.org](http://houstononevoice.org).
- Moffat, C. (2021, May 20). "Houston Still Lacks a Comprehensive Plan for Growth." BISNOW.
- Prof. Race presented his project, "Robins Landing Town Center: Strategies and Guidance for Resilience," at the American Planning Association Conference: Climate and Energy Positive Infill Development, November 2, 2021.
- Dr. Race's book chapter, "Eco-Districts in U.S. Cities: Policy Context, Protocols, and Effectiveness," was published in *Ecocities*, edited by Phillip Jones and Shan Shan Hou Gwyrrd Publishing, August 2021.
- Prof. Race participated in a virtual Houston-Galveston Area Council (H-GAC) EV Fleet Roundtable on April 14, 2022.



- Dr. Race has been invited to sit on the Houston-Galveston Area Council (H-GAC) Air Quality Planning Advisory Committee.
- Prof. Race appeared on Channel 13 Houston. (21, November 22). "A Texas company is at the center of a revolution in housing construction that aims to build more durable houses faster."
- Prof. Race presented his paper, "Pilot for Equitable Electric Mobility." (2021, October 1). University of Houston Energy Webinar Series.
- Dr. Race is serving on the Resilient Design Assistance Team. Houston One Voice (HOV). 501c-3 Formation Board, Ex-Officio. (2018-present).
- Prof. Race was guest critic at the University of Cincinnati, December 2021.
- KUHT Houston Public Media. (2021, October 13). "New study looks at how to make electric vehicles more accessible in Houston."
- Dr. Race presented his paper, "Net Zero Infill Development: Implementing Climate Action Plans," at the 2022 APA National Planning Conference, May 18-20.

## DEEPA RAMASWAMY

- Prof. Ramaswamy was awarded a \$16,000 grant from the Global Architecture History Teaching Collaborative (GAHTC) to conduct a workshop with invited architectural historians on the subject of the architecture history survey course and its futures. The workshop sessions were held virtually in January 2022 and produced material for the GAHTC web platform as well as for Deepa's ongoing work to revamp the architecture history survey sequence at our College.
- Prof. Ramaswamy was a guest critic, Urban Design Studio, CEPT University, India, Ungendering the Everyday City, 2nd + 3rd year Urban Assemblies: Radical Interventions in Loose Public Space, 3rd + 4th year Urban Design Studio
- Theorizing Architectural Production, 2nd + 3rd year Urban Design Studio Urban Assemblies Studio: The Vacancy Phenomenon, 4th year studio Urban design Studio.
- Prof. Ramaswamy's book chapter, "The Laws of Persuasion: Discretionary Zoning, Manageability and Rise of the Urban Designer in City

Government," *Neoliberalism on the Ground: Architecture and Transformation from the 1960s to the Present*, edited by Catherina Gabriellson, Helena Mattson and Kenny Cupers, University of Pittsburgh Press, 2021.

- "Review of Barrie Scardino Bradley's Improbable Metropolis," *Houston' Architectural and Urban History*, Arris, (The University of Texas Press, 2022, 363, Hardcover).
- 2022, "The Pilot at Etawah: Rural Redevelopment and the Making of a Self-Reformed Citizen," *Journal of Planning History* (accepted, working with editor).
- February 2022, "Of Land and Sea: Infrastructures, Reclamation, and Misinterpretations in Mumbai," College Art Association Annual Conference, Chicago.

## SHAFIK RIFAAT

- Prof. Rifaat's office building, 2402 Commonwealth, was cited in the *Texas Architect* article, "Almost All Right," by Kathryn O'Rourke, on the subject of archetypal gems of post-modern gems in Houston, November/December issue, p. 73.

## MARTA RODRIGUEZ

- Prof. Rodriguez is the Founder & Curator of *Habitable City*. Online journal. "Promoting a more egalitarian, connected, safe, and livable city." 2020-present.
- Prof. Rodriguez's new book, *Charlotte Perriand @ Kazuyo Sejima: Una Revolucion Sutil*, was published by Nobuk/Diseno Editorial, Madrid, Spain. The book highlights the relevance of Perriand and Sejima as initiators of a paradigm shift in Japanese, French, and present-day architecture. It addresses the transnational connections between Japan and France in the 1920s and 1980s.
- Graham Foundation Grant "Contemporary Japanese Architecture Through Kazuyo Sejima's Looking Glass." (Expected submission September 2022)

## SUSAN ROGERS

- *antiAtlas Journal* "Re-mapping the Neighborhood" features the work of Susan Rogers, the Community Design Resource Center, and Sheryl Tucker De Vazquez.
- The CDRC was featured in Houston 2020 exhibition at the Architecture Center

Houston's (ArCH) Houston 2020 Visions, an exhibition celebrating innovative, visionary project proposals that seek to place design and sustainability at the heart of the conversation about planning for a more resilient future.

- Susan Rogers participated on a panel on Tuesday September 22, 2020 sponsored by the Greater Houston Partnership "One Houston Together Webinar Series: Developing Equitable Communities."
- Susan Rogers and Katherine Polkinghorne, "Mapping Inequity in Houston's COVID-19 Vaccination Rollout," Kinder Institute for Urban Research, *Urban Edge Blog*, February 15, 2021.
- Susan Rogers and Katherine Polkinghorne, "Inequity Exists in Houston's Vaccination Efforts," in *CITE Digital*.
- Susan Rogers and Katherine Polkinghorne, Amplify: Design Agency and the Transportation Management," in AIA/ACSA Intersections Research Conference: Communities, Proceedings.
- Prof. Rogers has written a book chapter, "Tanks, Wellls, Tacos,

and Pitches," for *Informality and the City*, edited by Gregory Marinic and Pablo Meninato.

- Prof. Rogers, through her Community Design Resource Center, has completed a series of five public art installations titled, "Driving Jensen." The art installations, completed along Jensen Drive as part of the Driving Jensen project, included "We Are Jensen/Nostros Somos Jensen" billboard, "Family" bus shelter public art, "HOPE" sculpture, and "Reflecting Memories" wall. With community at its center, each project designed by the student teams depart from a point of optimism. The projects bring people together, build on assets, and elevate opportunities to amplify the history and meaning of public spaces throughout the corridor. Next time you are Driving Jensen, look around.
- The Driving Jensen project is part of a larger effort led by Houston Northeast CDC in collaboration with the University of Houston's Community Design Resource Center and the Greater Northside Management District. The project is funded by Houston LISC.



- Community Design Resource Center: Completed Funded Projects:

- I-45 Expansion, Community Workshops and Design Alternatives (2021). Funded by grants from the Houston Endowment (via the Houston Parks Board) and the Greater Northside Management District, \$135,000. Project Team: Susan Rogers, Director, Adelle Main, Angelica Lastra, Jose Mario Lopez, Gabriel Degetau, Katherine Polkinghorne, Cynthia Cruz, Maria Noguera.
- Moving From Plan to Action (2021). Funded by a \$30,000 grant from the National Endowment for the Arts and a \$15,000 grant from Mitsui Co. developed six projects from the five Collaborative Community Design Initiative projects over the last 12 years.
- Driving Jensen (2021). Funded by a \$50,000 grant from LISC. Project Team: Susan Rogers, Director, Adelle Main, Arianna Flick, Angelica Lastra, Jose Mario Lopez, Katherine Polkinghorne, Cynthia Cruz, Maria Noguera.

- Fifth Ward Quality of Life Agreement, LISC Houston (2021). The CDRC worked

in partnership with LISC Houston and the Fifth Ward Redevelopment Council to develop a sustainable community plan. Revenue contract amount \$44,500.

- Mayoral Proclamation, “Susan Rogers Day,” presented by Mayor Sylvester Turner, October 16, 2020.
- Rogers, Susan and Pena Nakouzi, Constanza. (2020) “The Little Home in Back” in *Columns Magazine*, Winter 2020 - Justice Issue - AIA Dallas, published May 2020.
- Rogers, Susan. “Designing for Impact: Building Hubs and Corridors in the Complete Communities.” Sponsored by the AIA Houston as part of the Houston 2020 Visions Lecture Series and the Mayor’s Office of Complete Communities. Invited Speaker, February 2, 2021 (virtual).
- Rogers, Susan. “Taking on the Megaproject: Houston and the I-45 Expansion” APA C3, Virtual Cross-Chapter Collaborative Conference. October 20, 2020. American Planning Association.\*\* (In collaboration with Oni Blair, Peter Eccles, and Christof Spieler)

- Prof. Rogers contributed a book chapter, “Look, See” to *More City than Water: A Houston Flood Atlas*, edited by Lacy M. Johnson and Cheryl Beckett, University of Texas Press, to be released May, 2022.

- Susan Rogers and Katherine Polkinghorne, “Driving Jensen,” *CITE Digital*, August 2021.
- Rogers, Susan. AIA Houston, Gulf Coast Green Keynote Panel Discussion. Invited Keyote Panelist. August 6, 2021 (virtual).
- Kacmar, Donna and Rogers, Susan with Anne-Elisabeth Baker, Miranda Gonzalez, Jolene Limqueco, and Sarah White. “Design Justice” presented at the national “Design + Diversity” Conference, August 7, 2021 (virtual).\*
- Kacmar, Donna and Rogers, Susan with Anne-Elisabeth Baker, Miranda Gonzalez, Jolene Limqueco, and Sarah White. “Design Justice” presented at Gulf Coast Green, August 6, 2021 (virtual).
- Rogers, Susan. “Is it a good neighborhood?” submitted for review to TU Delft’s proposed *Datapolis* publication.

- University of Houston, High Impact Publications and Creative Activities National Recognition Awards, Award Ceremony, November 12, 2020 (virtual).

- Prof. Rogers was the winner of the 24th annual EDRA Place-Planning Award for her work on the Greater Northside Urban Design Toolkit. The CDRC team included Susan Rogers, Adelle Main, Gabriela Degetau, Jose Mario Lopez, Constanza Pena, Angelica Lastra, and Barbara Venegas and the project was sponsored by the Greater Northside Management District.

### RONNIE SELF

- Prof. Self’s article, “Prose and Poetry: Houston and the Museum of Fine Arts.” In *The First Century* by Gary Tinterow, 30–47. Houston, TX, Museum of Fine Arts, Houston, 2020.

### JOSHUA SMITH

- Augmented Reality website for the *Living + Dying INBETWEEN the Real + the Virtual*. Co-director Peter Zweig.

### SHERYL TUCKER DE VAZQUEZ

- Prof. Vazquez’ students received an AIA Conceptual Design Award. The project was conceived in her ARCH 4500 studio. It was titled, “Strange Fruit: An Intervention at the Peace and Justice National Memorial” in Montgomery, Alabama.
- Prof. Vazquez, Felecia Davis (Penn State University), Marcella Del Signore (New York Institute of Technology), and William D. Williams (Rice University), received a Graham Foundation Grant Award for “Black Hair as Architecture.”
- Prof. Vazquez’ exhibition “Black Hair as Architecture” was exhibited at the Mashburn Gallery, Summer 2022.
- Prof. Vazquez’ “Black hair as Architecture: An Exhibition” was featured in *CITE Magazine*, 2022.

### KEVIN STORY

- The Complexities of John Hejduk’s Work: Exorcising Outlines, Apparitions, and Angels* has just been published by Routledge Research in Architecture.

### ROSS WIENERT

- Prof. Wienert’s paper, “Non-Square Grids: Voronoi Explorations in First Year Design,” was accepted for the National Conference on the Beginning Design Student.

### CELESTE PONCE WOODFILL

- Prof. Woodfill received a Texas Society of Architects’ 2020 Studio Award for her “Spec House.” The Studio Awards are given to recognize real or theoretical project that demonstrate excellence in design. The jury noted that, “There’s a strong, visible choice, an argument about how we live and transform those spaces.”

### PETER ZWEIG

- Matt Johnson, Peter Zweig, and Jason Logan have just published their book, *Houston: Genetic City*. The book was published by Actar Press.
- Prof. Zweig’s design for the Dr. S.S. Kumar House, in the office of William R. Jenkins Associates, was cited in the *Texas Architect* article, “Almost All Right,” by Kathryn O’Rourke, on the subject of archetypal gems of post-modern gems in Houston, November/December issue, p. 73.



- Prof. Zweig and William R. Jenkins project, Piper's Meadow Community Center, was cited in the *Texas Architect* article, "Almost All Right," by Kathryn O'Rourke, on the subject of archetypal gems of post-modern gems in Houston, November/December issue, p. 73.
- In October 2020, the exhibition *City of Refugees* opened at Aedes Architecture Forum in Berlin, Germany, alongside world-renowned activist and artist Ai Weiwei's *Purgatory*. *City of Refugees*, led by Hines College faculty members Peter Jay Zweig, FAIA, and Gail Peter Borden, FAIA, and including the work of three years of student studios, is a project of the College that is truly extraordinary. The interactive exhibition integrates augmented reality bringing it to life and allowing viewers to experience the exhibition beyond the physical models.
- Prof. Peter Zweig and Gail Peter Borden received an AIA Houston Design award for their "Non-Pavilion" for the Museum of Fine Arts Houston.
- Peter Zweig and Gail Peter Borden, *City of Refugees: A Search for Utopia*, was published by AR+D Publishers, 2021.
- Prof. Zweig and Gail Peter Borden were featured in an article by Wojciech Czaja, "City of the Stateless," *TOPOS Magazine*, Europe, November, 2021.
- Prof. Zweig and Rafael Beneytez-Duran co-designed the installation, *Airscapes for the 75th Anniversary Gala* of the college.
- Prof. Zweig and Gail Peter Borden designed three Mobil pavilions for the Museum of Fine Arts Houston.
- Prof. Zweig's book, *Living + Dying INBETWEEN the Real + the Virtual* has been published by AR+D Publishers. Summer 2022 distribution. (420 pages).
- Augmented Reality website for the *Living + Dying INBETWEEN the Real + the Virtual*. Co-director Josh Smith.





# STUDENT RECOGNITION AND AWARDS

## JOSHUA ALARCON

- In 2021, Joshua was chosen for the short list in the 15th China Hardware Products International Industrial Design Competition for his project Argo-Trace. His team included Anthony Lozano and Francisco Grandi.

## ALEXA BAEZA

- Alexa was recommended and accepted for the 2020 IIDC (International Integrated Design Camp) organized by the Korea Institute of Design Promotion (KIDP). Alexa was team leader and received first place.
- In 2021, Alexa was chosen on the short list for the 15th China Hardware Products International Industrial Design Competition for her project Medicycle.
- Alexa received the Outstanding Academic Achievement 2021 Design Award.
- Alexa received the 2021 IDSA Texas Chapter Special Recognition Award - Best Thesis - Honorable Mention.

- Alexa received the 2021 Myron C. Anderson Leadership Award.

## MILES OSADE BAILEY

- Miles received the 2022 IDSA Texas Chapter Special Recognition Award – Best Senior Project for his Sumu Brace – an orthotic stimulatory brace for children. A distinguished jury of professionals reviewed the projects and chose the top student projects.

## ANNE-ELISABETH BAKER

- Anne-Elisabeth received the 2022 Outstanding Academic Achievement Award for an undergraduate in Industrial Design.

## EDWIN BARAJAS

- Edwin, along with Mariana Galvan and Ferdous Kabir, received the 2021 Undergraduate Design Award - Second Place for their project, “Human Non-Human Collaboration Labs.”

## ANNA BIBIKOVA

- In 2021, Anna was recognized as the first-place winner of the Bienenstock Furniture Library Furniture Design Competition. Her design was developed and produced in INDS 3500, led by professors Jeff Feng and Aaron McEuen.

## CHRISTIAN BRISEÑO

- In 2020, Christian received the 2020 Alpha Rho Chi Award for Leadership at graduation.

## CARLOS SOTO CASTELLANOS

- Prof. Zweig’s student, Carlos Soto Castellanos, received an Honorable Mention in the ACSA Housing Competition: HERE & NOW: A House for the 21<sup>st</sup> Century for his Sky House. The competition had over 800 entries.

## EDGAR CASTILLO

- Edgar worked with Prof. Handanovic and six undergraduate Architecture students who joined forces with Houston’s Awty International School and non-profit organization Schools for Children of the World (SCW) to raise money and build a new school in a rural Buenos Aires village,

fifteen miles from Comayagua, Honduras. SCW and Awty International students raised more than \$23,000, with the total cost of construction for the project estimated to be \$22,000.

## FRANCO DENARI

- Franco received the 2021 Undergraduate Architecture Design Award - Best Project of the Year for “The Coin, The Crack and The Cistern.”

## GASTON DENARI

- Gaston, along with Sharon Philip received the 2021 Undergraduate Architecture Design Award - Honorable Mention for “Walled City.”

## DANIELA DIAZ

- Daniela received the 2022 Outstanding Design Award for Interior Architecture.

## LAWRENCE DILLON

- Lawrence received the 2020 IDSA Student Merit Award at Graduation, 2020.

## DAVID EDQUILANG

- David received the 2022 IDSA Houston Chapter Undergraduate Student Merit Award. As an

undergraduate student, Zain will represent the College at the district and national level for IDSA Student Merit Award.

## DRAKE FLOOD

- Architecture student Drake Flood was published in the *Texas Architect* magazine. His article, “Practicing Sustainable Architecture in the Oil and Gas Capital of the World,” analyzes the work of Gail and Joe Adams in Houston.
- Drake received the 2022 Nia Becnel Award. The award is named for Nia Bechnel who was a community activist, preservationist, and Hines College professor.

## MARIANA GALVAN

- Mariana, along with Edwin Barajas and Ferdous Kabir, received the 2021 Undergraduate Design Award - Second Place for their project, “Human Non-Human Collaboration Labs.”

## USNA GHAFAR

- Usna received the 2021 Alpha Rho Chi Leadership Award.

## LUIS GONZALES

- Luis received the 2020 Myron C. Anderson Leadership Award at Graduation, 2020.

## NIELL GORMAN

- Prof. Feng and Niell Gorman’s paper, “Enhancing Prosthetic Hand Functionality with Elastic 3D-Printed Thermoplastic Polyurethane,” was accepted to the Applied Human Factors and Ergonomics 12th International Conference in July.
- Niell received the 2021 IDSA Texas Chapter Special Recognition Award - Best Thesis - First Place.

## FRANCISCO GRANDI

- Francisco was chosen for the short list in the 15<sup>th</sup> China Hardware Products International Industrial Design Competition for his project Argo-Trace. His team included Anthony Lozano and Joshua Alarcon.
- Francisco received the 2021 IDSA Texas Chapter Special Recognition Award - Best Thesis - Second Place.



## **ANNALEISE GRAY**

- Annaleise became a finalist and won the bronze award in the 15<sup>th</sup> China Hardware Products International Industrial Design Competition. This is the first time the College has entered and we were the only competitors from the United States. Annaleise created Hippo – a collapsible scooter and backpack.
- Annaleise received the 2021 IDSA Texas Chapter Special Recognition Award - Best Thesis - Honorable Mention.

## **STEVEN GRIFFIN**

- Steven worked with Prof. Handanovic and six undergraduate Architecture students who joined forces with Houston's Awty International School and non-profit organization Schools for Children of the World (SCW) to raise money and build a new school in a rural Buenos Aires village, fifteen miles from Comayagua, Honduras. SCW and Awty International students raised more than \$23,000, with the total cost of construction for the project estimated to be \$22,000.

## **KATHLEEN HARTMAN**

- Kathleen received the 2022 Myron C. Anderson Award for Leadership. The award, named for Professor Myron Anderson, is given to a student whose efforts exemplify commitment to others and efforts to engender collegiality and high purpose as important aspects of an architect's service to society.

## **HANNAH HEMMER**

- Hannah received the AIA Academic Excellence Award for achieving the highest academic standing in a professional degree program at the graduate level.

## **DIANA HERNANDEZ**

- Diana was named to the short list for the 15<sup>th</sup> China Hardware Products International Industrial Design Competition for her project Neo.

## **KARLA HERNANDEZ**

- Karla received the Outstanding Academic Achievement Award for and undergraduate in Environmental Design.

## **RUKAIYA JAMALI**

- Rukaiya, along with Sharon Lott, received the 2021 Undergraduate Design Award - Honorable Mention for "Pockets of Home."

## **ZAIN JAMJOOM**

- Zain received the 2022 Outstanding Academic Achievement Award for a graduate student in Industrial Design.
- Zain received the 2022 IDSA Houston Chapter Graduate Student Merit Award. As a graduate student Zain will represent the College at the district and national level for IDSA Student Merit Award.

## **PERLA JAUREGUI**

- Perla received the 2021 Henry Adams Medal for the Bachelor of Architecture program.

## **DYMON JOHNSON**

- Industrial Design '19 alumnus, Dymon was named a finalist in The International Society of Furniture Designers for its 2020 Pinnacle Awards. Dymon's furniture concept, The INK SERIES occasional tables, incorporated an innovative construction method

utilizing compressed laminated recycled newspapers.

## **AUSTIN JONES**

- Austin received the 2020 Henry Adams Medal for the Master of Architecture program at Graduation.
- Austin received the 2020 Graduate Architecture Design Award, "The Lodge at Big Bend National Park," at Graduation.

## **FERDOUS KABIR**

- Ferdous, along with Edwin Barajas and Mariana Galvan, received the 2021 Undergraduate Design Award - Second Place for their project, "Human Non-Human Collaboration Labs."

## **CHRISTOPHER KIRCH**

- Christopher received the 2021 Henry Adams Medal for the Master of Architecture program.
- Christopher received 2021 Graduate Architecture Design Award - Second Place for "(RE)BUILD."

## **MARIANA KEYMOLEN**

- Mariana received a 2021 IDSA Student Merit Award.

## **SHARON LOTT**

- Sharon, along with Rukaiya Jamali, received the 2021 Undergraduate Design Award - Honorable Mention for "Pockets of Home."

## **ANTOINETTE LOUW**

- Antoinette received the 2020 IDSA Texas Chapter Special Recognition Award for Best Thesis at Graduation.

## **ANTHONY LOZANO**

- Anthony was chosen for the short list in the 15<sup>th</sup> China Hardware Products International Industrial Design Competition for his project Argo-Trace. His team included Joshua Alarcon and Francisco Grandi.

## **MASON LUCICH**

- INSU Health Design is a start-up founded by Mason Lucich, an ID Graduate student (2019) with an innovation developed in the I+E Lab (Innovation + Entrepreneurship).
- This year, INSU Health Design has won some major grants. Most notables: VentureWell Aspire Award Phase 2. It includes a \$20,000 fund and business mentor training.

- Top winner team in the Bravo Family Foundation program (\$60K plus further support).

## **PATRICK HUGO MARGAIN**

- Patrick received the 2022 Undergraduate Design Award – Runner Up for his project "La Quebrada de Acapulco." The design awards were chosen by a jury of distinguished professionals/educators.

## **DANIELLE MARTINEZ**

- Danielle received the 2020 Outstanding Thesis for Interior Architecture at Graduation, 2020.

## **CALEB MATHESON**

- Caleb Matheson and Darci McGee won a Merit Award from the AIA Fort Worth Excellence in Architecture Student Design Awards for their project Lewis Center.
- Caleb received the 2022 Undergraduate Design Award – Runner Up for his project Against the Slope. The design awards were chosen by a jury of distinguished professionals/educators.



## **DARCI MCGEE**

- Darci McGee and Caleb Matheson won a Merit Award from the AIA Fort Worth Excellence in Architecture Student Design Awards for their project Lewis Center.

## **ELVIA MELENDEZ**

- Elvia received the 2020 Undergraduate Architecture Design Award – Honorable Mention for Downtown Hybrid Opertions at Graduation.

## **MORGAN MENDENHALL**

- Morgan worked with Prof. Handanovic and six undergraduate Architecture students who joined forces with Houston’s Awty International School and non-profit organization Schools for Children of the World (SCW) to raise money and build a new school in a rural Buenos Aires village, fifteen miles from Comayagua, Honduras. SCW and Awty International students raised more than \$23,000, with the total cost of construction for the project estimated to be \$22,000.

## **ANDREW MENDINA**

- Andrew worked with Prof. Handanovic and six undergraduate Architecture students who joined forces with Houston’s Awty International School and non-profit organization Schools for Children of the World (SCW) to raise money and build a new school in a rural Buenos Aires village, fifteen miles from Comayagua, Honduras. SCW and Awty International students raised more than \$23,000, with the total cost of construction for the project estimated to be \$22,000.

## **MARGARET MERRILL**

- Margaret received the 2020 Outstanding Academic Achievement in Undergraduate Interior Architecture award at Graduation.

## **MARIELLE MORGAN**

- Marielle received the 2021 Graduate Architecture Design Award - Honorable Mention for “Urban Attraction.”

## **SARAH NEIMAN**

- Sarah worked with Prof. Handanovic and six undergraduate Architecture

students who joined forces with Houston’s Awty International School and non-profit organization Schools for Children of the World (SCW) to raise money and build a new school in a rural Buenos Aires village, fifteen miles from Comayagua, Honduras. SCW and Awty International students raised more than \$23,000, with the total cost of construction for the project estimated to be \$22,000.

## **CHRIS NGUYEN**

- Chris worked with Prof. Handanovic and six undergraduate Architecture students who joined forces with Houston’s Awty International School and non-profit organization Schools for Children of the World (SCW) to raise money and build a new school in a rural Buenos Aires village, fifteen miles from Comayagua, Honduras. SCW and Awty International students raised more than \$23,000, with the total cost of construction for the project estimated to be \$22,000.

## **KENNY NGUYEN**

- Kenny received the Outstanding Academic Achievement 2021 Design Award.

## **MICHELLE OVANESSIONS**

- Michelle Ovanessians and Kieran Renfrow won an AIA Fort Worth Excellence in Architecture Student Design Merit Award for their project Homecoming. The jury stated, “The project’s unique take on community building is very interesting, both in a material capacity and in an experiential capacity.”

## **GIULIANA PEDRESCHI**

- Giuliana received the 2020 Undergraduate Architecture Design Award – Honorable Mention for “Protest and Theater in São Paulo” at Graduation.

## **ANDREINA PEREIRA**

- Andreina received the 2021 Withit Scholarship.

## **ELSY DANIELA MIRANDA PEREZ**

- Elsy received the AIA Academic Excellence Award for achieving the highest academic standing in a professional degree program at the undergraduate level.

## **LAUREN PETERS**

- Lauren received the 2020 IDSA Texas Chapter Special Recognition Award for Leadership at Graduation.

## **SHARON PHILIP**

- Sharon, along with Gaston Denari received the 2021 Undergraduate Architecture Design Award - Honorable Mention for “Walled City.”

## **KATHERINE “KAEDE” POLKINGHORNE**

- Katherine received the 2021 Undergraduate Design Award - Honorable Mention for “Freeway Architecture of Biopolitical Disobedience.”
- Katherine received the 2021 Nia Becnel Leadership Award.

## **COLETTE RABITTOY**

- Colette received the 2020 Undergraduate Architecture Design Award for Best in Show, “Ghosting IM Pei,” at Graduation.

## **KIERAN RENFROW**

- Kieran Renfrow and Michelle Ovanessians won an AIA Fort Worth Excellence in Architecture Student Design Merit Award for their project Homecoming. The jury stated, “The project’s unique take on community building is very interesting, both in a material capacity and in an experiential capacity.”

## **DAVID RINCON**

- David received the 2022 Undergraduate Design Award – Honorable Mention for his project Cycles of the Columbia Tap. The design awards were chosen by a jury of distinguished professionals/educators.

## **KIMBERLY SAAVEDRA**

- Kimberly received the Outstanding Academic Achievement 2021 Design Award.



## **JENNY SARABIA**

- Jenny received the 2020 Graduate Architecture Design Award for Best Master Project Neo-Retro Detroit at Graduation.

## **ROXANA SAENZ**

- Roxana received the 2020 Graduate Architecture Design Award, "Laredo Gateway," at Graduation.

## **PETRA SALAMEH**

- Petra received the 2020 Design Award for Best in Show, "After Modernism in Amman," at Graduation.

## **ANA SEVILLA**

- Ana received the Architecture Research Center Consortium King Medal and Award. Named in honor of the late Jonathan King, co-founder and first president of the Architectural Research Centers Consortium (ARCC), this award is given to one student per ARCC member college, school, institute, or unit. Selection of recipients is at the discretion of the individual member

institutions, but is based upon criteria that acknowledge innovation, integrity, and scholarship in architectural and/or environmental design research.

- Ana received the 2022 Undergraduate Design Award – First Place for her project "Liquid Dissidents." The design awards were chosen by a jury of distinguished professionals/educators.

## **RAJVI SHAH**

- Rajvi received the 2020 Graduate Architecture Design Award for his project "Gandhi Indian Cultural Center" at Graduation.

## **HILLARY TELOGRAFO**

- Prof. Race's team was selected as one of the four finalists for the 19th Annual Hines Competition. There were 105 entries. Bruce Race's Sustainable Urban Systems graduate student, Jie Yang, and Keith Richards' MBA student, Jose Medina, were the team leaders.

## **LIYA THOMAS**

- Liya received the 2011 IDSA Texas Chapter Recognition Award - Best Thesis - Third Place.

## **JOAQUIN TINOCO**

- Joaquin received the 2011 IDSA Texas Chapter Recognition Award - Leadership.

## **JAMES TORRES**

- James received the 2021 Graduate Architecture Design Award - Best Master Project for "Verticulture."

## **OMULOLU UWADINMA**

- Omulolu received the 2021 Graduate Architecture Design Award - Honorable Mention for "More Home, Less Institution."

## **NYX VALERDY**

- Nyx received the 2020 Alpha Rho Chi Award presented to a graduating senior who has shown an affinity for leadership, performed willing service for the school and gives promise of professional merit through their attitude and personality.

## **CAMERON WHITE**

- Cameron received the 2020 Outstanding Academic Achievement in Graduate Industrial Design award at Graduation.

## **SARAH WHITE**

- Sarah worked with Prof. Handanovic and six undergraduate Architecture students who joined forces with Houston's Awty International School and non-profit organization Schools for Children of the World (SCW) to raise money and build a new school in a rural Buenos Aires village, fifteen miles from Comayagua, Honduras. SCW and Awty International students raised more than \$23,000, with the total cost of construction for the project estimated to be \$22,000.

- Sarah received the 2022 Outstanding Academic Achievement Award as an undergraduate in Interior Design.

## **BRONWYN WISMER**

- Bronwyn received the 2020 Henry Adams Medal for the Bachelor of Architecture program at Graduation.

## **TESS WRIGHT**

- Tess received the 2020 Nia Becnel Leadership Award at Graduation.

## **JIE YANG**

- Prof. Race's team was selected as one of the four finalists for the 19th Annual Hines Competition. There were 105 entries. Bruce Race's Sustainable Urban Systems graduate student, Jie Yang, and Keith Richards' MBA student, Jose Medina, were the team leaders.

## **BETHANY GRACE YEH**

- Bethany received the 2022 Undergraduate Design Award – Honorable Mention for her project Redesigning the Work-Space. The design awards were chosen by a jury of distinguished professionals/educators.









Gerald D. Hines College  
of Architecture and Design

---

UNIVERSITY OF HOUSTON